

# Operating Instructions

**Fronius Primo GEN24 208-240**

7.7 / 10.0

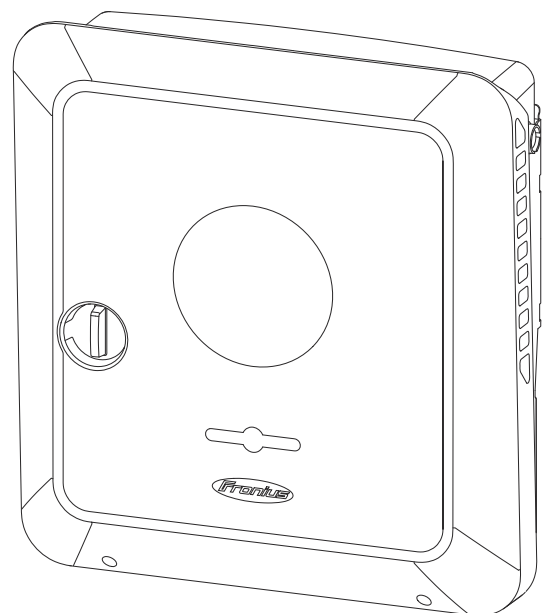

**EN-US** | Operating instructions





# Table of contents

|  |           |
|--|-----------|
| Safety rules.....  | 6         |
| Explanation of safety instructions.....                  | 6         |
| Safety.....  | 6         |
| General.....   | 6         |
| Environmental conditions.....                            | 7         |
| Qualified personnel.....                                 | 7         |
| Data on noise emission values.....                       | 7         |
| EMC measures.....  | 8         |
| Backup power.....  | 8         |
| Equipment grounding (GND).....                           | 9         |
| <b>General information</b>                               | <b>11</b> |
| Fronius Primo GEN24.....                                 | 13        |
| Device concept.....                                      | 13        |
| Function overview.....                                   | 13        |
| Scope of supply.....                                     | 14        |
| Intended use.....  | 14        |
| Thermal concept.....                                     | 15        |
| Data backup.....   | 15        |
| Fronius Solar.web.....                                   | 15        |
| Local communication.....                                 | 16        |
| Different operating modes.....                           | 17        |
| Operating modes – Explanation of symbols.....            | 17        |
| Operating mode - Inverter with Smart Meter.....          | 18        |
| Operating mode – Inverter with several Smart Meters..... | 18        |
| Protection of people and equipment.....                  | 19        |
| Rapid shutdown.....                                      | 19        |
| Power Line Communication (PLC) transmitter.....          | 20        |
| Additional external AC and/or DC disconnect.....         | 21        |
| WSD (wired shutdown).....                                | 21        |
| RCMU.....  | 21        |
| Insulation Monitoring.....                               | 21        |
| AFCI - Arc Fault Circuit Interrupter (Arc Guard).....    | 21        |
| Standby state.....                                       | 22        |
| Surge protection device.....                             | 22        |
| Operating controls and connections.....                  | 23        |
| Connection area.....                                     | 23        |
| Connection area divider.....                             | 24        |
| Ground electrode terminal.....                           | 24        |
| DC disconnect.....                                       | 25        |
| Data communication area.....                             | 25        |
| Button functions and LED status indicator.....           | 26        |
| Schematic internal wiring of IOs.....                    | 28        |
| <b>Backup power variant - PV Point (OP)</b>              | <b>29</b> |
| General.....   | 31        |
| PV Point (OP).....                                       | 31        |
| Explanation - PV Point (OP).....                         | 31        |
| <b>Installation</b>                                      | <b>33</b> |
| General.....   | 35        |
| Quick-fastener system.....                               | 35        |
| Warning notices on the device.....                       | 35        |
| Installation location and position.....                  | 37        |
| Choosing the location of the inverter.....               | 37        |
| Installation position of the inverter.....               | 39        |
| Knockouts.....   | 41        |

|  |           |
|--|-----------|
| Preparing knockouts for connection.....                                      | 41        |
| Installing the mounting bracket and attaching the inverter.....              | 42        |
| Selecting the mounting material.....   | 42        |
| Properties of the mounting bracket.....                                      | 42        |
| Do not deform the mounting bracket.....                                      | 42        |
| Fitting the mounting bracket to a wall.....                                  | 42        |
| Installing the mounting bracket on a mast or beam.....                       | 43        |
| Attaching the mounting bracket to mounting rails.....                        | 44        |
| Attaching the inverter to the mounting bracket.....                          | 44        |
| Requirements for connecting the inverter.....                                | 45        |
| Various cable types.....   | 45        |
| Permitted cables for the electrical connection.....                          | 45        |
| Cable diameter for push-in terminals.....                                    | 46        |
| Permitted cables for the data communication connection.....                  | 46        |
| Maximum alternating current fuse protection.....                             | 47        |
| Connecting the inverter to the public grid (AC side).....                    | 49        |
| Safety.....  | 49        |
| Suitable grids.....  | 49        |
| Connecting the inverter to the public grid (AC side).....                    | 50        |
| Connecting solar module strings to the inverter.....                         | 53        |
| General information about PV modules.....                                    | 53        |
| Safety.....  | 53        |
| PV generator, general.....   | 54        |
| Module array configuration 7.7 - 10.0 kW.....                                | 54        |
| Connecting solar module strings to the inverter.....                         | 55        |
| Connecting backup power - PV Point (OP).....                                 | 59        |
| Safety.....  | 59        |
| Installation.....  | 60        |
| Connecting the data communication cables.....                                | 63        |
| Modbus participants.....   | 63        |
| Routing data communication cables.....                                       | 64        |
| Terminating resistors.....   | 64        |
| Installing the WSD (wired shutdown).....                                     | 66        |
| Closing and commissioning the inverter.....                                  | 67        |
| Closing the inverter's connection area/housing cover, and commissioning..... | 67        |
| Starting the inverter for the first time.....                                | 67        |
| Installation with the app.....   | 68        |
| Installation with the browser.....   | 68        |
| De-energizing the inverter and switching it back on.....                     | 70        |
| De-energizing the inverter and switching it back on.....                     | 70        |
| <b>Settings – User interface of the inverter</b> .....                       | <b>71</b> |
| User settings.....   | 73        |
| User login.....  | 73        |
| Selecting languages.....   | 73        |
| Device configuration.....  | 74        |
| Components.....  | 74        |
| Functions and I/Os.....  | 74        |
| Inverter.....  | 74        |
| Load management.....   | 78        |
| Load management.....   | 78        |
| System.....  | 79        |
| General.....   | 79        |
| Update.....  | 79        |
| Setup wizard.....  | 79        |
| Restoring factory settings.....  | 79        |
| Event log.....   | 79        |
| Information.....   | 79        |
| License manager.....   | 80        |
| Support.....   | 80        |
| Communication.....   | 82        |



|  |            |
|--|------------|
| Network.....   | 82         |
| Modbus.....  | 83         |
| Remote control .....                                       | 84         |
| Fronius Solar API.....                                     | 85         |
| Internet services.....                                     | 85         |
| Safety and grid requirements.....                          | 86         |
| Country setup.....   | 86         |
| Requesting inverter codes in Solar.SOS .....               | 86         |
| Feed-in limit.....   | 87         |
| I/O power management.....                                  | 88         |
| Connection diagram - 4 relays.....                         | 88         |
| I/O power management settings - 4 relays .....             | 90         |
| Connection diagram - 3 relays.....                         | 91         |
| I/O power management settings - 3 relays .....             | 92         |
| Connection diagram - 2 relays.....                         | 93         |
| I/O power management settings - 2 relays .....             | 94         |
| Connection diagram - 1 relay.....                          | 95         |
| I/O power management settings - 1 relay .....              | 96         |
| <b>Appendix</b>  | <b>97</b>  |
| Service, maintenance and disposal .....                    | 99         |
| General.....   | 99         |
| Copyright.....   | 99         |
| Maintenance.....   | 99         |
| Cleaning.....  | 99         |
| Safety .....   | 99         |
| Operation in dusty environments .....                      | 100        |
| Disposal.....  | 101        |
| Warranty provisions .....                                  | 102        |
| Fronius manufacturer's warranty.....                       | 102        |
| Status codes and remedy.....                               | 103        |
| Display.....   | 103        |
| Status codes.....  | 103        |
| Technical data.....  | 104        |
| Technical data for Fronius Primo GEN24 7.7 208 - 240.....  | 104        |
| Technical data for Fronius Primo GEN24 10.0 208 - 240..... | 107        |
| WLAN.....  | 111        |
| Explanation of footnotes .....                             | 111        |
| Integrated DC disconnecter .....                           | 112        |
| <b>Circuit Diagrams</b>                                    | <b>113</b> |
| Emergency power terminal—PV Point (OP).....                | 115        |
| Circuit diagram.....                                       | 115        |
| <b>Dimensions of the inverter</b>                          | <b>117</b> |
| Fronius Primo GEN24 7.7 - 10.0 208-240 .....               | 119        |
| Fronius Primo GEN24 7.7 - 10.0 208-240 .....               | 119        |

# Safety rules

---

## Explanation of safety instructions

### **WARNING!**

**Indicates a potentially dangerous situation.**

- ▶ Death or serious injury may result if appropriate precautions are not taken.
- 

### **CAUTION!**

**Indicates a potentially harmful situation.**

- ▶ Minor injury or damage to property may result if appropriate precautions are not taken.
- 

### **NOTE!**

**Indicates a possibility of flawed work results and possible damage to the equipment.**

---

Please pay special attention when one of the symbols from the "Safety rules" chapter appears in these instructions.

---

## Safety

### **IMPORTANT!**

This unit must be operated in accordance with the technical specifications data-sheet. This document is available on the corporate website of the manufacturer.

### **CAUTION!**

**Danger from crushing due to the incorrect handling of attachments and connection parts.**

Injuries to limbs may result.

- ▶ To avoid muscle strain or injury, use proper lifting techniques and if required use a lifting aid.
  - ▶ When lifting up, putting down, and attaching the inverter, use the integrated grips.
  - ▶ When fitting any attachments, ensure that no limbs are located between the attachment and the inverter.
  - ▶ Do not hold onto the terminals when locking and unlocking.
- 

## General

This device has been manufactured with quality control procedures and is in compliance with established safety regulations. However, improper use or misuse may pose potential risks including:

- Serious or fatal injury to the operator or third parties
  - Damage to the device and other material assets belonging to the property owner
- 

All personnel involved in commissioning, maintenance, and servicing of the device must:

- Be suitably qualified to perform electrical work, as defined by the NFPA 70
  - Have knowledge of and experience in dealing with electrical installations
  - Have fully read and precisely followed these Operating Instructions
-

All installations must comply with national and local electrical codes and standards.

---

In addition to the Operating Instructions, all applicable local regulations regarding accident prevention and environmental protection must also be followed.

---

All safety and danger notices on the device:

- Must be kept in a legible state
  - Must not be damaged
  - Must not be removed
  - Must not be covered, pasted or painted over
- 

Only operate the device when all protection devices are fully functional. If the protection devices are not fully functional, there is a danger of:

- Serious or fatal injury to the operator or third parties
  - Damage to the device and other material assets belonging to the property owner
- 

Any safety devices that are not fully functional must be repaired by an authorized specialist before the device is switched on.

---

Never bypass or disable protection devices.

---

For the location of the safety and danger notices on the device, refer to the chapter headed "Warning notices on the device" in the Operating Instructions for your device.

---

Any equipment malfunctions which impair safety must be remedied before the device is turned on.

---

---

### **Environmental conditions**

Operation or storage of the device outside the stipulated area will be deemed as not in accordance with the intended purpose. The manufacturer accepts no liability for any damage resulting from improper use.

---

### **Qualified personnel**

The servicing information contained in these Operating Instructions is intended only for the use of qualified personnel as defined by the NFPA 70. An electric shock can be fatal. Do not carry out any actions other than those described in the documentation.

---

All cables and leads must be secured, undamaged, insulated, and adequately dimensioned. Loose connections, scorched, damaged, or under-dimensioned cables and leads must be repaired immediately by qualified personnel.

---

Maintenance and repair work must only be carried out by an authorized specialist.

---

It is impossible to guarantee that externally (aka, third-party) procured parts are designed and manufactured to meet the demands made on them, or that they satisfy safety requirements. Use only original spare parts (also applies to standard parts).

---

Do not carry out any alterations, installations, or modifications to the device without first obtaining the manufacturer's permission.

---

Components that are not in perfect condition must be changed immediately.

---

### **Data on noise emission values**

The sound pressure level of the inverter is indicated in the [Technical data](#).

---

The cooling of the device takes place via an electronic temperature control system at the lowest possible noise level and depends on the power used, ambient temperature, and the soiling level of the device, etc.

---

It is not possible to provide a workplace-related emission value for this device, because the actual sound pressure level is heavily influenced by the installation situation, the power quality, the surrounding walls, and the properties of the room in general.

---

### **EMC measures**

In certain cases, even though a device complies with the standard limit values for emissions, it may affect the application area for which it was designed (e.g., when there is equipment that is susceptible to interference at the same location or if the site where the device is installed is close to either radio or television receivers). If this is the case, the operator is obliged to take action to rectify the situation.

---

### **Backup power**

This system has backup power functions. A replacement power supply can be established in the event of a failure in the public grid.

---

Maintenance and installation work in the home network requires both disconnection on the network side and deactivation of the replacement power mode by opening the integrated DC disconnect on the inverter.

---

Depending on the irradiance conditions, the backup power supply is automatically deactivated and activated. This can cause the backup power supply to unexpectedly return from standby mode. Therefore, installation work can only be performed on the home network when the PV disconnect is switched OFF. This action shall deactivate the backup power supply.

---

#### **Influencing factors on the total output in backup power mode:**

##### **Reactive power**

Electrical loads with a power factor not equal to 1 require reactive power as well as effective power. The reactive power places a further load on the inverter. To correctly calculate the actual total output, it is therefore the current produced by the effective and reactive power, and not the rated power, that is relevant.

Devices with a high reactive power are predominantly electric motors, such as:

- Water pumps
- Circular saws
- Fans

##### **High starting/start-up current**

Electrical loads that need to accelerate a large mass generally require a high starting/start-up current. This can be up to ten times the nominal current. The maximum current of the inverter is available for the starting/start-up current. Loads with too high a starting/start-up current cannot, therefore, be started/operated, even though the nominal power of the inverter suggests otherwise. The connected load power and the starting/start-up current must therefore be taken into account when it comes to sizing the backup power circuit.

Devices with a high starting/start-up current include:

- Devices with electric motors (e.g., lift platforms, circular saws, workbenches)
- Devices with a high transmission ratio and flywheel mass
- Devices with compressors (e.g., compressed air compressors, air-conditioning systems)

**IMPORTANT!**

Very high start-up currents can temporarily distort or interrupt the output voltage. Simultaneous operation of electronic devices in the same backup power grid should be avoided.

**IMPORTANT!**

The inverter may only be operated within the limits of its technical capabilities. Operation outside of its technical capabilities can cause the inverter to shut down.

---

**Equipment  
grounding (GND)**

Grounding a point in the device, system, or installation serves as a protective measure against electric shock in the event of a fault. When installing an inverter from safety class 1 (see [Technical data](#)), a ground conductor connection is required.

When connecting the ground conductor, ensure that it is secured to prevent unintentional disconnection. All of the points listed in the chapter headed [Connecting the inverter to the public grid \(AC side\)](#) on page 49 must be observed. When using strain-relief devices, it is important to ensure that the ground conductor is loaded last in the event of a failure. The respective national standards and regulations and requirements for minimum cross-section must be observed when connecting the ground conductor.



# **General information**





# Fronius Primo GEN24

## Device concept

The inverter transforms the direct current generated by the PV modules into alternating current. This alternating current is fed into the public grid and synchronized with the mains voltage in use.

The inverter is intended for use in grid-connected photovoltaic systems. For the configuration of photovoltaic systems, Fronius provides the application Solar.creator, available at <https://creator.fronius.com/>.

The Fronius repowering tool (<https://repowering.fronius.com/>) supports installers and Fronius System Partners with repowering existing photovoltaic systems.

The inverter has backup power functions and switches to backup power mode if it has been wired accordingly\*.

The inverter automatically monitors the public grid. Whenever conditions in the electric grid are inconsistent with standard conditions (e.g., grid switch-off, interruption), the inverter will stop producing power and interrupt the supply of power into the grid in conformance with IEEE standards.

The grid is monitored by monitoring the voltage, frequency, and islanding conditions.

After installation and commissioning, the inverter's operation is fully automatic; the inverter draws the maximum possible power from the PV modules. Depending on the operating point, this power is used in the home or fed into the grid.

As soon as the energy provided by the PV modules is no longer sufficient, the power is drawn from the public grid.

When its temperature gets too high, the inverter automatically reduces the current output power or switches off completely, in order to protect itself. Reasons for the temperature being too high include a high ambient temperature or insufficient heat dissipation (e.g., inadequate heat dissipation when installed in switch cabinets or in direct sunlight).

\* Depending on the device variant, corresponding cabling, settings, and local standards and regulations.

## Function overview

| Function                             | Primo GEN24 208-240   |
|--------------------------------------|---|
| Backup power variant - PV Point (OP) |  |

## Scope of supply

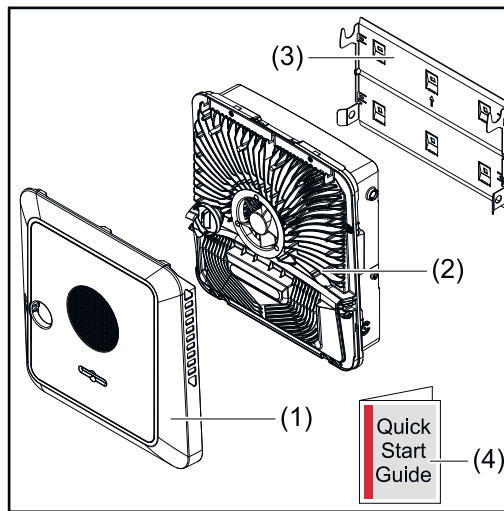

- (1) Housing cover
- (2) Inverter
- (3) Mounting bracket (illustration)
- (4) Quick Start Guide

## Intended use

The inverter is designed to convert direct current from PV modules into alternating current and feed this power into the public grid. A backup power mode\* is possible if the appropriate cabling has been installed.

The following are deemed not to comply with the intended purpose:

- Utilization for any other purpose or in any other manner
- Alterations to the inverter are not permitted if they are not expressly recommended by Fronius
- Installation of components is not permitted if these are not expressly recommended or sold by Fronius

The manufacturer is not responsible for any damage resulting from improper use. All warranty claims are considered void in such cases.

Intended use also means:

- Carefully reading and obeying all the instructions, as well as safety and danger notices in the Operating Instructions
- Installation in accordance with the chapter headed "**Installation**", from page **33**

When configuring the photovoltaic system, make sure that all photovoltaic system components are operating exclusively within their permitted operating range.

Follow all grid operator regulations regarding grid power feed and connection methods.

The Fronius GEN24 inverter is a grid-connected inverter with backup power function and is not a stand-alone inverter. The following restrictions in backup power mode must therefore be observed:

- The inverter may be operated for max. 2000 operating hours in backup power mode
- The inverter may be operated for more than 2000 operating hours in backup power mode provided 20% of the grid power feed operating time of the inverter is not exceeded at the time in question

\* Depending on the device variant, settings and local standards and regulations.

---

## Thermal concept

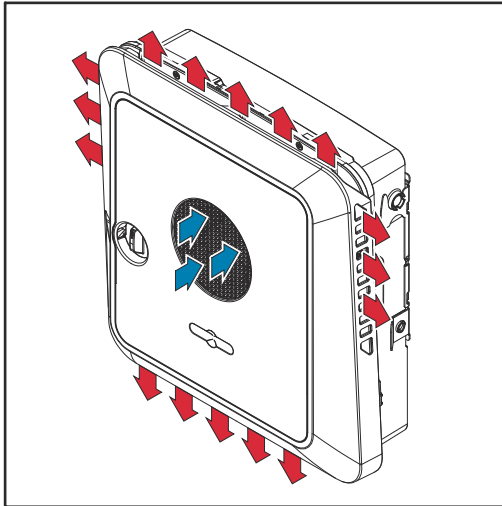

Ambient air is drawn in at the front of the device by the fan and blown out at the sides. The even heat dissipation allows several inverters to be installed next to each other.

### NOTE!

#### Risk due to insufficient cooling of the inverter.

This may result in a loss of power in the inverter.

- ▶ Do not block the fan (e.g., with objects that protrude through the touch guard).
- ▶ Do not cover the ventilation slots, even partially.
- ▶ Make sure that the ambient air can always flow through the inverter's ventilation slots unimpeded.

---

## Data backup

The user is responsible for backing up any changes made to the factory settings. The manufacturer accepts no liability for any deleted personal settings.

---

## Fronius Solar.web

System owners and installers can easily monitor and analyze the PV system using Fronius Solar.web or Fronius Solar.web Premium. With the appropriate configuration, the inverter transmits data such as power, yield, load, and energy balance to Fronius Solar.web. More detailed information can be found at [Solar.web - Monitoring & analysis](#).

Configuration is carried out using the Setup wizard; see the chapter headed [Installation with the app](#) on page 68 or [Installation with the browser](#) on page 68.

#### Requirements for configuration:

- Internet connection (download: min. 512 kbit/s, upload: min. 256 kbit/s)\*.
- User account at [solarweb.com](http://solarweb.com).
- Completed configuration using the Setup wizard.

\* These specifications do not provide an absolute guarantee of flawless operation. High error rates in the transmission, fluctuating receptions or misfires can have an adverse effect on data transfer. Fronius recommends on-site testing to ensure that the connections meet the minimum requirements.

---

**Local communication**

The inverter can be found via the Multicast DNS (mDNS) protocol. We recommend searching for the inverter using the assigned host name.

The following data can be called up via mDNS:

- NominalPower
- Systemname
- DeviceSerialNumber
- SoftwareBundleVersion

# Different operating modes

---

## Operating modes – Explanation of symbols



**PV module**  
generates direct current

---



**Fronius GEN24 inverter**  
converts direct current into alternating current. The integrated system monitoring enables the inverter to be integrated into a network by means of WLAN or LAN.

---



**Additional inverter in the system**  
converts the direct current into alternating current. However, it cannot charge a battery, and is not available in backup power mode.

---



**Primary meter**  
records the load curve of the system and makes the measured data available for energy profiling in Fronius Solar.web. The primary meter also regulates the dynamic feed-in control.

---



**Secondary meter**  
records the load curve of individual loads (e.g., washing machine, lights, television, heat pump, etc.) in the load branch and makes the measured data available for energy profiling in Fronius Solar.web.

---



**Loads in the system**  
are the loads connected in the system.

---



**Additional loads and producers in the system**  
which are connected to the system by means of a Smart Meter.

---



**PV Point**  
is a non-interruption-free 1-phase backup power circuit, which supplies electrical devices up to a maximum output of 3.12 kW, provided sufficient power is available from the PV modules.

---



**Grid**  
supplies the loads in the system if insufficient power is being generated by the PV modules.

**Operating mode  
- Inverter with  
Smart Meter**

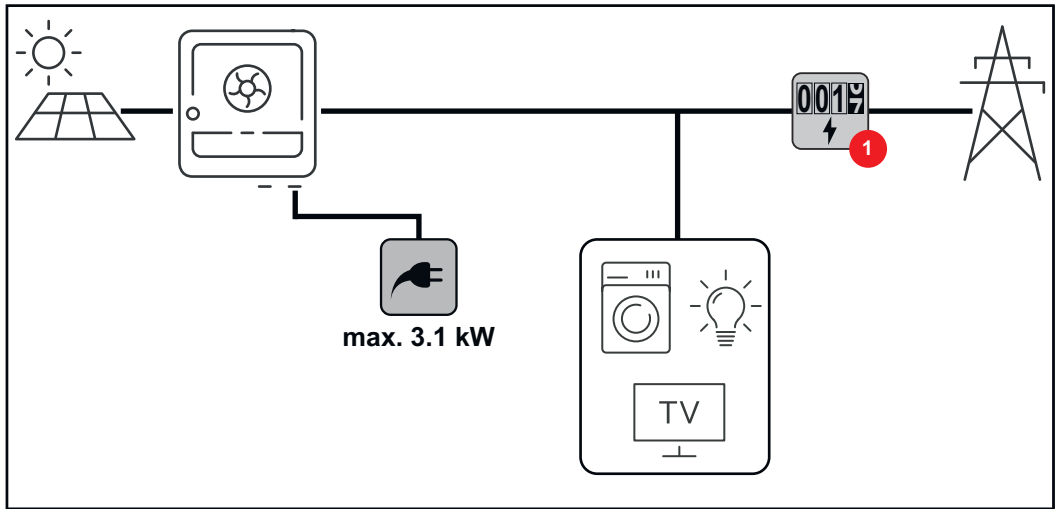

**Operating mode  
- Inverter with  
several Smart  
Meters**

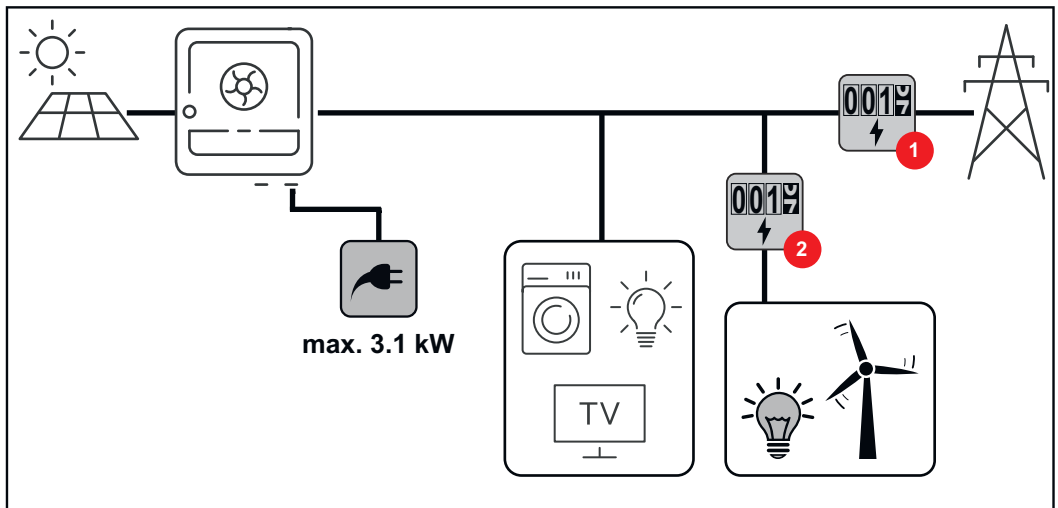

# Protection of people and equipment

**Rapid shutdown** Two different types of rapid shutdown (RSD) can be triggered depending on the configuration and on-site installation:

- **Via external buttons:** One or more external buttons can be installed on the WSD (wired shutdown) interface of the **Data communication area** on page 25. Pressing one of these buttons interrupts the communication from the inverter to the rapid shutdown devices attached to the PV modules, only if they correspond to the SunSpec standard for rapid shutdown. The terminals are discharged to  $< 30$  VDC and  $< 15$  VAC within 30 seconds after RSD initiation.
- **Via the loss of the grid connection:** An automatic rapid shutdown can also occur if the grid connection is lost. The inverter identifies a failure of the grid connection and terminals are discharged to  $< 30$  VDC and  $< 15$  VAC. The inverter also interrupts the communication to the shutdown devices of the PV modules if they correspond to the SunSpec standard for rapid shutdown.

 **WARNING!**

**Limited rapid shutdown function in backup power mode (PV Point and Full Backup)**

If PV Point or Full Backup is configured, rapid shutdown cannot be triggered via the loss of grid connection. This can result in serious personal injury and damage to the PV system.

- ▶ A WSD switch must be installed for all backup power modes (PV-Point and Full Backup) (see **Installing the WSD (wired shutdown)**). The rapid shutdown is then triggered via WSD.

Self test error automatic: RsdSelftestFailed

When an RSD occurs, an entry appears in the Event Log menu: RsdTriggeredByLossOfAc (interruption by AC breaker) or RsdTriggeredBySwitch (interruption by WSD circuit)

In case a module-level shutdown equipment within the PV array is used in combination with the inverter, this labeling has to be used according to NEC (Section 690.12), CEC (Section 64-218):

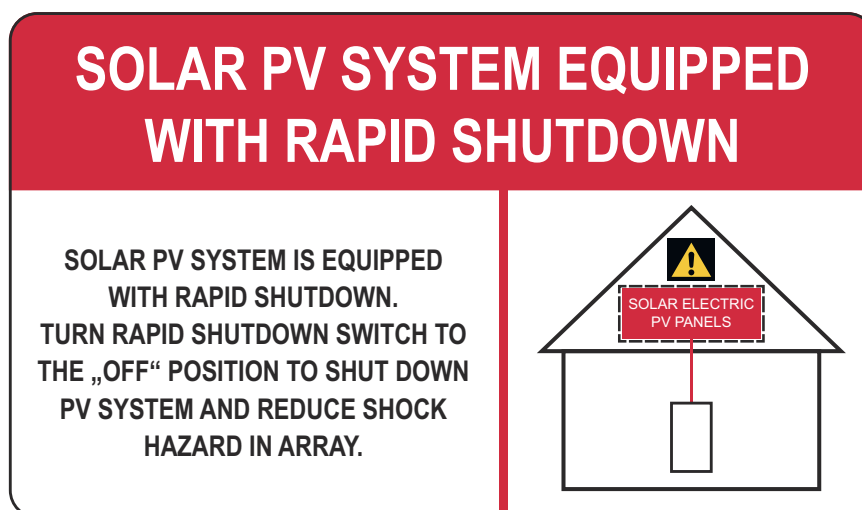

In case a string-level shutdown equipment at the PV array is used in combination with the inverter, this labeling has to be used according to NEC (Section 690.12), CEC (Section 64-218):

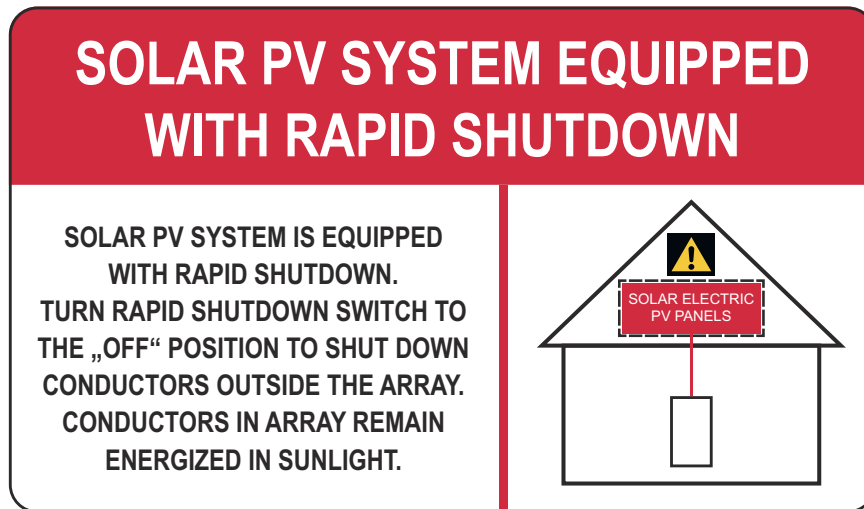

**Warning** - The installer is responsible for the correct labeling of the PV system. The rapid shutdown requirement of the inverter is not affected by the FRT (fault ride through) capability, so the inverter is „Grid support interactive compatible“.

**Warning** - This photovoltaic rapid shutdown equipment (PVRSE) does not perform all of the functions of a complete photovoltaic rapid shutdown system (PVRSS). This PVRSE must be installed with other equipment to form a complete PVRSS that meets the requirements of NEC (NFPA 70) section 690.12 for controlled conductors outside the array. Other equipment installed in or on this PV system may adversely affect the operation of the PVRSS. It is the responsibility of the installer to ensure that the completed PV system meets the rapid shutdown functional requirements. This equipment must be installed according to the manufacturer's installation instructions.

#### **Self-test**

A self-test of the RSD function can be performed manually or automatically. The automatic self-test relates only to the discharge circuit of the RSD function. All other RSD circuit components are produced so as to be fail-safe.

Sequence of automatic self-test:

In each startup procedure—prior to connection to the public grid—when there is sufficient DC voltage (40 V) the discharge circuit is activated for 10 ms and the feedback pin is checked prior to and during charging.

Sequence of manual self-test:

A manual self-test can be triggered by an interruption in the grid connection (e.g., AC breaker) or by the WSD trigger device (see also [WSD \(wired shutdown\)](#) on page 21).

The discharge must be measured and checked using a multimeter.

---

#### **Power Line Communication (PLC) transmitter**

The inverter is equipped with a Power Line Communication (PLC) transmitter on the DC side.

Its function is to ensure rapid shutdown in accordance with US safety standard NEC 2023 Art. 690.12. The PLC is implemented according to the specification "Communication Signal for Rapid Shutdown – SunSpec Interoperability Specification". Please visit [www.sunspec.org](http://www.sunspec.org) for details.



To ensure compliance with all applicable regulations in your country and to ensure optimal reception among all recipients, please follow the recommendations below:

- Keep the distance between the DC+ and DC- conductors as small as possible
- Avoid cable loops caused by cables that are too long (coil effect)
- Use metal cable ducts where possible
- Do not place DC cables from different inverters in the same cable duct or cable tray

---

**Additional external AC and/or DC disconnect**

Depending on the installation, an additional external AC and/or DC disconnect may be required if the inverter is installed in a location not easily accessible to utility or first responders. Contact your local authorities for additional information.

---

**WSD (wired shutdown)**

The wired shutdown (WSD) interrupts the inverter's grid power feed if the trigger device (switch, e.g., Emergency Stop or fire alarm contact) has been activated.

If an inverter (slave) fails, it is bypassed and the other inverters continue operating. If a second inverter (slave) or the inverter (master) fails, the operation of the entire WSD chain is interrupted.

For installation, see [Installing the WSD \(wired shutdown\)](#) on page 66.

---

**RCMU**

The inverter is equipped with an RCMU (RCMU = residual current monitoring unit) according to UL1741 CRD 3rd Edition (Non-Isolated EPS Interactive PV Inverters).

It monitors residual currents from the PV module up to the AC output and disconnects the inverter from the grid when an improper residual current is detected. If five faults are detected within a period of 24 hours, grid power feed operation can also be permanently interrupted until a manual reconnection has been performed.

---

**Insulation Monitoring**

In the case of PV systems with ungrounded PV source circuits, the inverter checks the resistance between the positive or negative pole of the PV system and the earth potential before feeding energy into the grid. In the event of a short circuit between the DC+ or DC- cable and ground (e.g. due to inadequately insulated DC cables or damaged solar modules), the inverter is prevented from feeding energy into the grid.

---

**AFCI - Arc Fault Circuit Interrupter (Arc Guard)**

An AFCI (arc fault circuit interrupter) protects against arc faults and, in the narrower sense, is a protection device in the event of contact errors. The AFCI evaluates faults that occur in the current and voltage flow on the DC side using an electronic circuit and shuts down the circuit if a contact error is detected. This significantly reduces potential overheating and fire risk at poor contact points.



## CAUTION!

### **Danger from faulty or incorrect DC installation.**

This may result in a risk of damage and, as a consequence, risk of fire in the PV system due to prohibited thermal loads that occur during an arc.

- ▶ Check the plug connections to ensure that they are correct.
  - ▶ Repair faulty insulation correctly.
  - ▶ Perform connection work in line with the instructions.
- 

### **IMPORTANT!**

Fronius will not bear any costs for production downtimes, installation costs, etc., which may arise due to a detected electric arc and its consequences. Fronius accepts no liability for damage which may occur despite the integrated Arc Fault Circuit Interrupter/interruption (e.g., due to a parallel arc).

### **IMPORTANT!**

Active PV module electronics (e.g., power optimizers) can impair the function of the Arc Fault Circuit Interrupter. Fronius cannot guarantee the correct function of the Arc Fault Circuit Interrupter in combination with active PV module electronics.

### **Reconnection behavior**

Grid power feed operation is interrupted for at least 5 minutes after an arc has been detected. Depending on the configuration, grid power feed operation is then automatically resumed. If several arcs are detected within a period of 24 hours, grid power feed operation can also be permanently interrupted until a manual reconnection has been performed.

---

### **Standby state**

If one of the following safety devices is triggered, the inverter switches to the standby state:

- Rapid shutdown
- WSD
- RCMU
- Insulation monitoring
- AFCI

In the standby state, the inverter no longer feeds in and is disconnected from the grid by the opening of the AC relay.

---

### **Surge protection device**

The inverter is equipped with an integrated surge protection device according to UL1741 3rd Edition, CSA-C22.2 No.107.1-16 on the DC (Category II) and AC (Category IV) side. The surge protection device protects the system against damage caused by overvoltage.

If the integrated surge protection devices become damaged due to prolonged overvoltage exposure, the damage may not be covered under the terms of warranty. See warranty terms for more information.

# Operating controls and connections

## Connection area

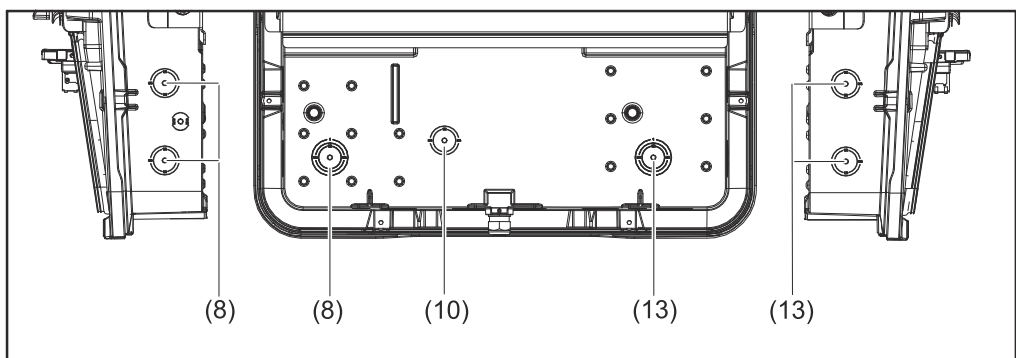
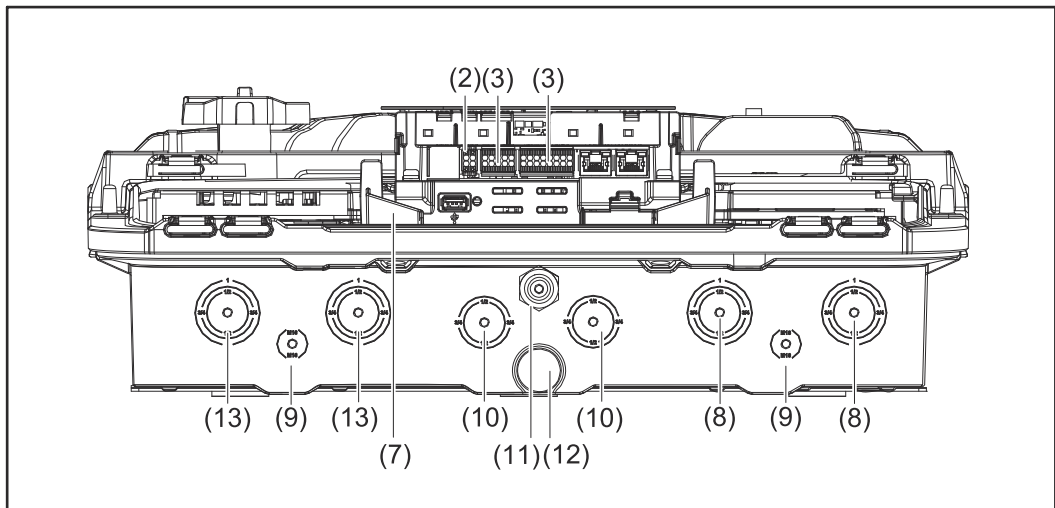
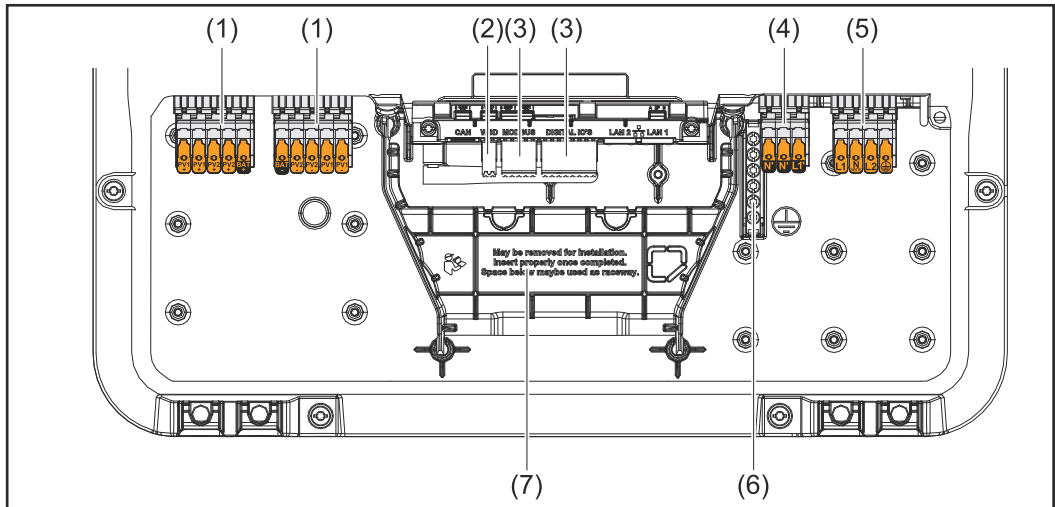

- (1) 2 x 5-pin DC push-in terminal
- (2) Push-in WSD (wired shutdown) terminal
- (3) Push-in terminals in the data communication area (Modbus, digital inputs and outputs)
- (4) 3-pin push-in terminal for PV Point (OP)
- (5) 4-pin AC push-in terminal
- (6) 6-pin ground electrode terminal

- (7) Connection area divider
- (8) AC conduit connection ( $\varnothing$  ½ - 1 inch / 13 - 25 mm)
- (9) Ground spike conduit connection ( $\varnothing$  5/8 inch / 16 mm)
- (10) DatCom conduit connection ( $\varnothing$  ½ - ¾ inch / 13 - 19 mm)
- (11) Data communication area conduit connection
- (12) Drain valve
- (13) DC conduit connection ( $\varnothing$  ½ - 1 inch / 13 - 25 mm)

**Connection area divider**

The connection area divider separates the high-voltage conductors (DC and AC) from the signal lines. To make it easier to reach the connection area, the divider can be removed for the connection work, and must be re-inserted.

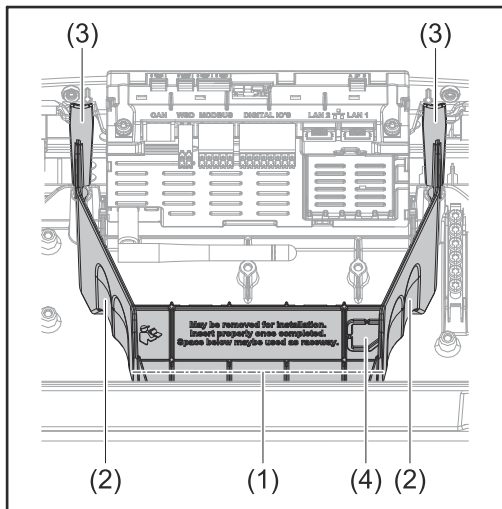

- (1) Integrated cable duct
- (2) Recesses for removing the connection area divider
- (3) Snap tabs for locking/unlocking
- (4) Defined breaking point for the DatCom connection

The integrated cable duct (1) allows for the lines to be laid from one area of the inverter to the other. As a result, multiple inverters can be easily installed next to each other.

**Ground electrode terminal**

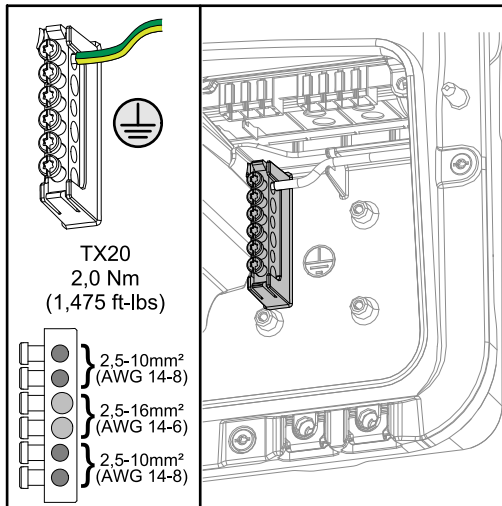

The ground electrode terminal  $\oplus$  provides the option of grounding additional components, such as:

- AC cable
- Module mounting system
- Ground spike

## DC disconnect

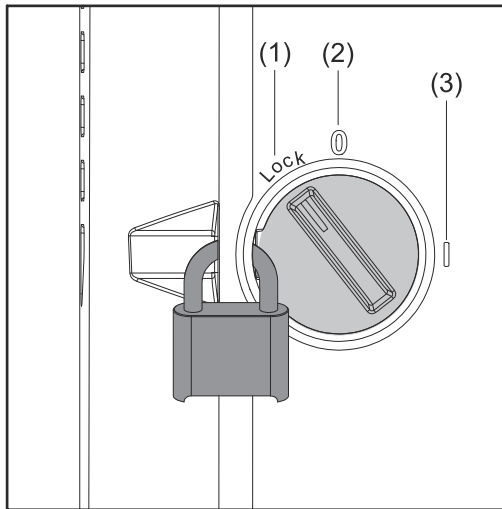

The DC disconnect has three switch settings:

- (1) Locked/off (turned to the left)
- (2) Off
- (3) On

### IMPORTANT!

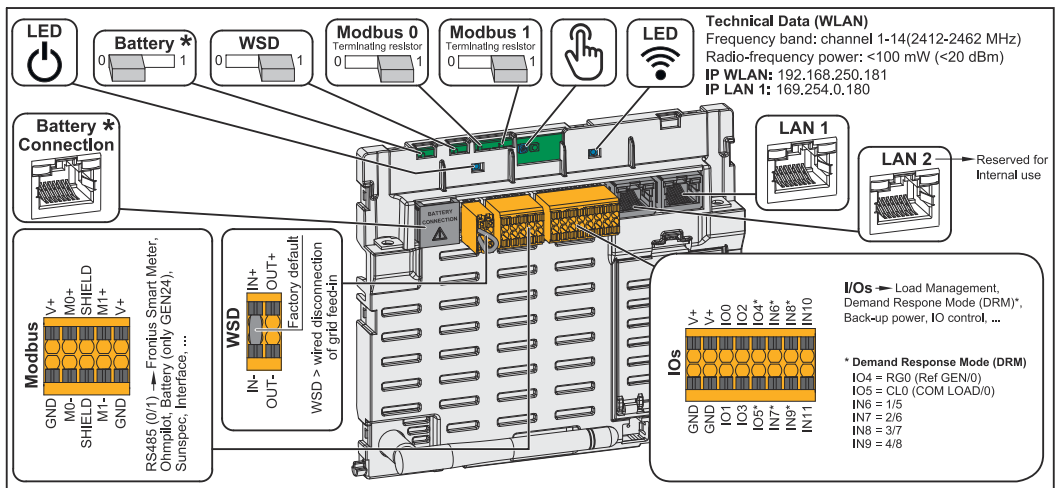

In switch settings (1) and (3), the inverter can be secured to prevent it from being switched on/off using a standard padlock. The national guidelines must be complied with in this respect.

## Data communication area



\*Please note that the BAT (RJ45) interface is reserved for future use and is not currently available.

|   |   |
|---|---|
| <p><b>Operating LED</b></p>               | <p>Indicates the inverter operating status.</p>   |
| <p><b>WSD (wired shutdown) switch</b></p> | <p>Defines the inverter as the WSD master or WSD slave.</p> <p><b>Position 1:</b> WSD master<br/><b>Position 0:</b> WSD slave</p>   |
| <p><b>Modbus 0 (MBO) switch</b></p>       | <p>Switches the terminating resistor for Modbus 0 (MBO) on/off.</p> <p><b>Position 1:</b> Terminating resistor on (factory setting)<br/><b>Position 0:</b> Terminating resistor off</p> |
| <p><b>Modbus 1 (MB1) switch</b></p>       | <p>Switches the terminating resistor for Modbus 1 (MB1) on/off.</p> <p><b>Position 1:</b> Terminating resistor on (factory setting)<br/><b>Position 0:</b> Terminating resistor off</p> |

|   |   |
|---|---|
|  <b>Optical sensor</b>     | For operating the inverter. See the chapter headed <b>Button functions and LED status indicator</b> on page 26.   |
|  <b>Communications LED</b> | Indicates the inverter connection status.   |
| <b>LAN 1</b>  | Ethernet connection for data communication (e.g., WLAN router, home network or, for commissioning with a laptop, see the chapter headed <b>Installation with the browser</b> on page 68).   |
| <b>LAN 2</b>  | Reserved for future functions. To avoid malfunctions, only use LAN 1.   |
| <b>I/O terminal</b>   | Push-in terminal for digital inputs/ outputs. See the chapter headed <b>Permitted cables for the data communication connection</b> on page 46.  |
| <b>WSD terminal</b>   | Push-in terminal for the WSD installation. See the chapter headed " <b>WSD (wired shutdown)</b> " on page 21.   |
| <b>Modbus terminal</b>  | Push-in terminal for the installation of Modbus 0, Modbus 1, 12 V, and GND (ground).<br><br>The data connection to the connected components is established via the Modbus terminal. <b>The inputs M0 and M1 can be freely selected.</b> Max. 4 Modbus participants per input; see the chapter headed <b>Modbus participants</b> on page 63. |

### Button functions and LED status indicator

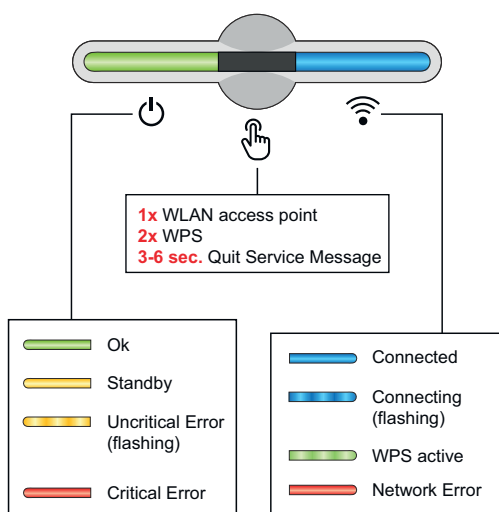







The status of the inverter is shown via the operating status LED. In the event of faults, carry out the individual steps in the Fronius Solar.start app.



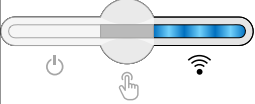

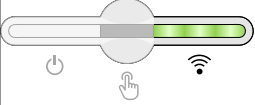

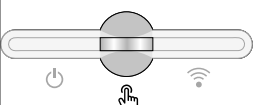



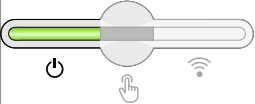

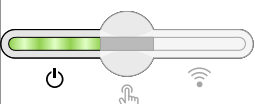

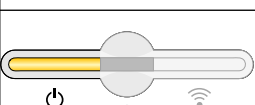

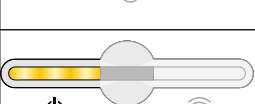

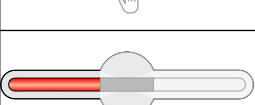

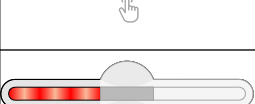

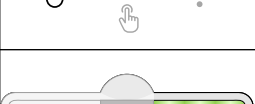
The optical sensor is actuated by touching with a finger.

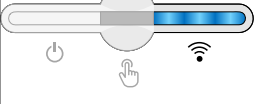

The status of the connection is shown via the communication LED. To establish the connection, carry out the individual steps in the Fronius Solar.start app.

| Sensor functions  |   |
|---|---|
|  | 1x  = WLAN Access Point (AP) is opened.<br> Flashing blue                                       |
|  | 2x  = WLAN Protected Setup (WPS) is activated.<br> Flashing green                               |
|  | 3 seconds  (max. 6 seconds) = the service message is acknowledged.<br> Flashing white (rapidly) |

| LED status indicator  |  |
|---|--|
|    | The inverter is operating correctly.<br> Lights up green  |
|    | The inverter is performing the grid checks required by the applicable standards for feed-in mode.<br> Flashing green  |
|   | The inverter is in standby, is not operational (e.g. no feed-in at night) or is not configured.<br> Lights up yellow  |
|  | The inverter indicates a non-critical status.<br> Flashing yellow   |
|  | The inverter indicates a critical status and there is no grid power feed process.<br> Lights up red   |
|  | The inverter indicates a backup power overload.<br> Flashing red  |
|  | The network connection is being established via WPS.<br>2x  = WPS search mode.<br> Flashing green                                |
|  | The network connection is being established via WLAN AP.<br>1x  = WLAN AP search mode (active for 30 minutes).<br> Flashing blue |
|  | The network connection is not configured.<br> Lights up yellow  |

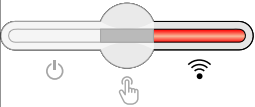
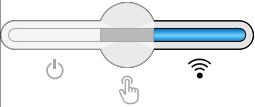
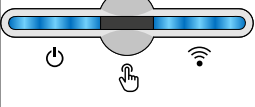
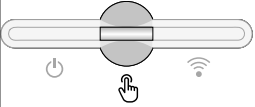
| LED status indicator  |   |
|---|---|
|  | The inverter is operating correctly, a network fault is indicated.<br><br>📶 Lights up red |
|  | The network connection is active.<br><br>📶 Lights up blue                                 |
|  | The inverter is performing an update.<br><br>🔌 / 📶 Flashing blue                          |
|  | There is a service message.<br><br>👉 Lights up white                                      |

### Schematic internal wiring of IOs

The V+/GND pin provides the possibility of feeding in a voltage in the range of 12.5 to 24 V (+ max. 20%) using an external power supply unit. Outputs IO 0 - 5 can then be operated using the external voltage that has been fed in. A maximum of 1 A may be drawn per output, whereby a total of max. 3 A is permitted. The fuse protection must take place externally.

### ⚠️ CAUTION!

**Danger from polarity reversal at the terminals due to improper connection of external power supply units.**

This may result in severe damage to the inverter.

- ▶ Check the polarity of the external power supply unit with a suitable measuring device before connecting it.
- ▶ Connect the cables to the V+/GND outputs while ensuring the correct polarity.

### IMPORTANT!

If the total output (6W) is exceeded, the inverter switches off the entire external power supply.

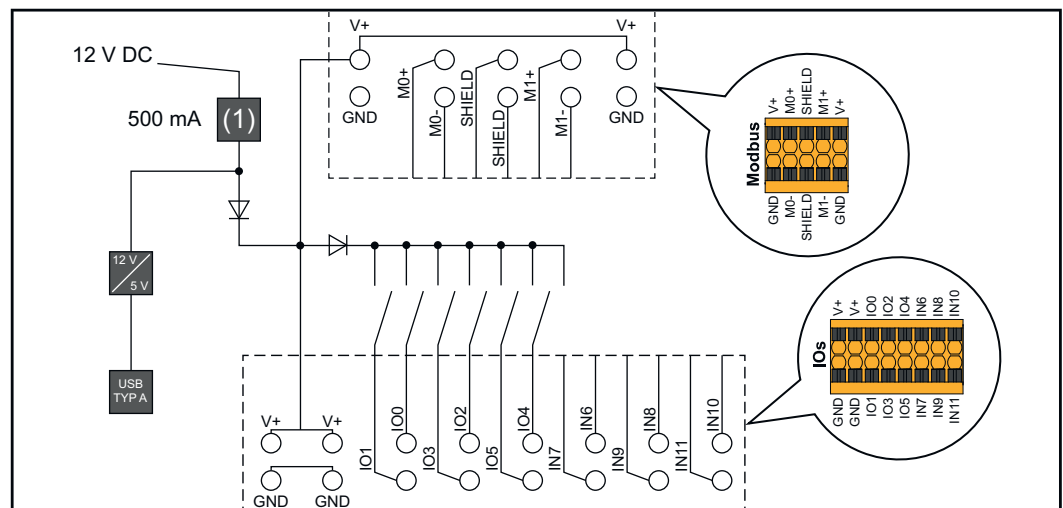

(1) Current limitation



# **Backup power variant - PV Point (OP)**



# General

## PV Point (OP)

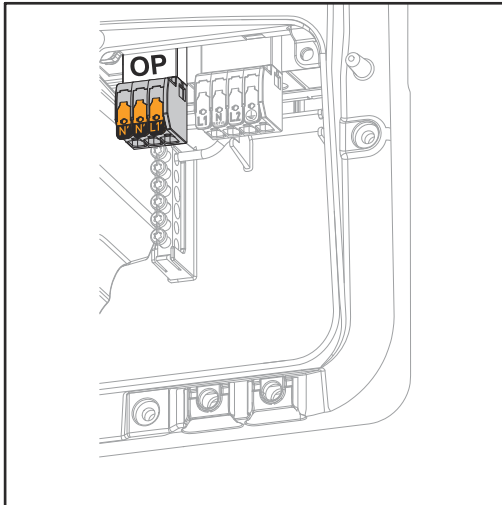

### WARNING!

#### Limited rapid shutdown function in backup power mode (PV Point and Full Backup)

If PV Point or Full Backup is configured, rapid shutdown cannot be triggered via the loss of grid connection. This can result in serious personal injury and damage to the PV system.

- ▶ A WSD switch must be installed for all backup power modes (PV Point and Full Backup) (see [Installing the WSD \(wired shutdown\)](#)). The rapid shutdown is then triggered via WSD.

With the PV Point, in the event of a failure of the public grid, electrical devices can be connected to the Opportunity Power (OP) terminal and supplied with a maximum power of 3.1 kW, if enough power is available in the PV modules. In grid-connected operation, the OP terminal is not supplied with voltage, therefore the connected loads will not be supplied with power in this operating mode.

#### IMPORTANT!

A grid switchover with relay is not possible.

## Explanation - PV Point (OP)

With the default settings, the inverter can provide 120V at the PV Point. A corresponding configuration must be set up during commissioning.

At the selected output voltage, a maximum of 13 A AC continuous current is available. The maximum continuous output is 1560 W.

#### Example:

$$120 \text{ V} * 13 \text{ A} = 1560 \text{ W}$$

In backup power mode, some electrical appliances cannot function properly as start-up currents are too high (e.g., fridges and freezers). In backup power mode, we recommend switching off non-essential loads. Overload capacity of 35% is possible for a duration of 5 seconds, depending on the current power of the PV module.

There is a brief interruption when switching from grid-connected mode to backup power mode. As a result, the backup power function cannot be used as an uninterruptible power supply, for computers, for example.

If no energy from the PV modules is available in backup power mode, backup power mode ends automatically. Backup power mode restarts again automatically once sufficient energy can once again be provided by the PV modules.

In the event of excessive loads, backup power mode is stopped and the "Backup power overload" status code is displayed on the inverter's LED status indicator. The maximum power in backup power mode specified in the technical data must be observed.

# Installation



# General

## Quick-fastener system

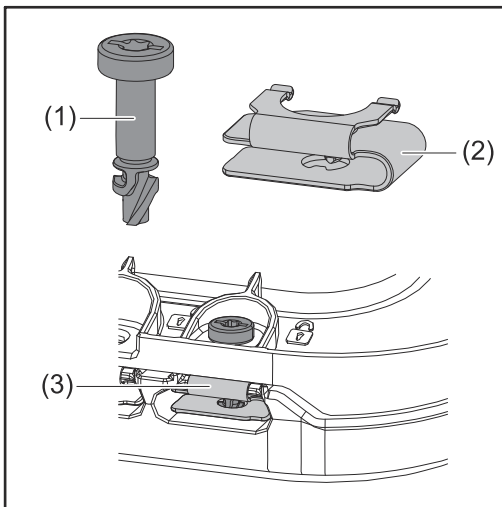

A quick-fastener system (3) is used to mount the connection area cover and front cover. The system is opened and closed with a half-rotation (180°) of the captive screw (1) into the quick-fastener spring (2).

The system is independent of torque.

### NOTE!

#### Danger when using a drill driver.

This may result in the destruction of the quick-fastener system due to over-torque.

- ▶ Use a screwdriver (TX20).
- ▶ Do not turn the screws more than 180°.

## Warning notices on the device

Warning notices and safety symbols are located on the inverter. These warning notices and safety symbols must not be removed or painted over. They warn against incorrect operation, as this may result in serious injury and property damage.

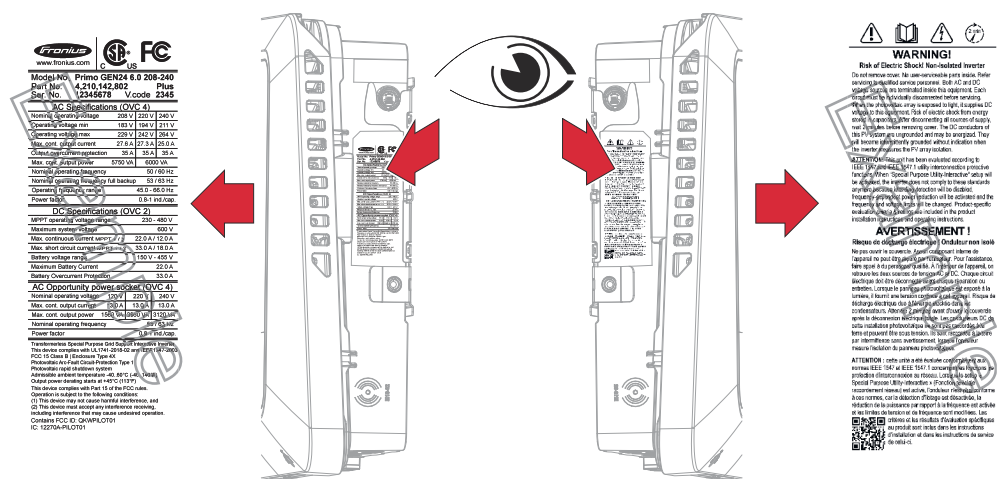

### Symbols on the rating plate:



Devices marked with the CSA certification mark satisfy the requirements of the relevant product standards for Canada and the USA.



This device complies with Part 15 of the FCC Rules. Operation is subject to the following conditions:

- This device must not cause any harmful interference.
- This device must not be affected by external sources of interference, including interference that may impair operation.

**Safety symbols:**



Danger of serious injury and property damage due to incorrect operation



Do not use the functions described here until you have fully read and understood the following documents:

- These Operating Instructions
- All Operating Instructions for the system components of the photovoltaic system, especially the safety rules



Dangerous electrical voltage



Allow the capacitors of the inverter to discharge (2 minutes).

**Warning notice text:**

**WARNING!**

An electric shock can be fatal. Before opening the device, ensure that the input and output sides are de-energized.



# Installation location and position

## Choosing the location of the inverter

### NOTE!

#### Risk from unsuitable choice of location for the inverter.

Failure or restricted operation of the inverter may result.

- ▶ Adhere to the instructions relating to the location, according to this chapter
- ▶ Adhere to national provisions and guidelines when installing the inverter.

Please note the following criteria when choosing a location for the inverter:

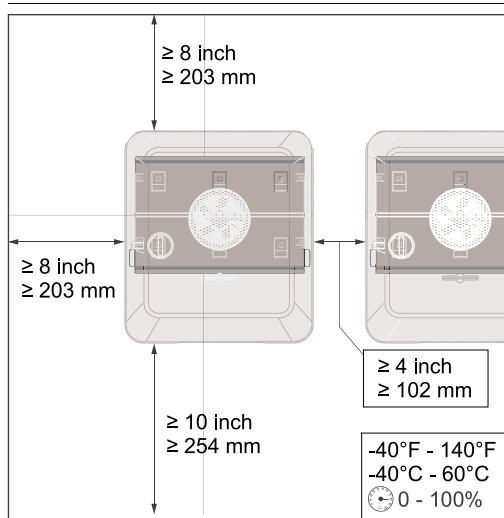

Only install on a solid, non-flammable surface.

Max. ambient temperatures:  
-40 °F - +140 °F / -40 °C - 60 °C

Relative humidity:  
0 - 100%

When installing the inverter in a switch cabinet or similar closed environment, it is necessary to make sure that the hot air that develops will be dissipated by forced-air ventilation.

For more detailed information on inverter dimensions, refer to the chapter headed **Fronius Primo GEN24 7.7 - 10.0 208-240** on page **119**.

When installing the inverter on the outer walls of cattle sheds, it is important to maintain a minimum clearance of 6.5 ft between all sides of the inverter and the ventilation and building openings.

The following substrates are permissible for installation:

- Walls ( non-flammable surfaces sufficiently capable of bearing loads):
  - Corrugated metal walls [mounting rails]
  - Brick walls
  - Concrete walls
  - Vinyl siding walls
  - Wood siding walls
  - Stucco wall
- Poles (installed using mounting rails, behind the PV modules directly on the PV mounting system)
- Covered parking lot roofs (no overhead installation)

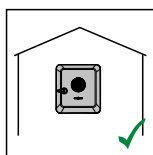

The inverter is suitable for indoor installation.

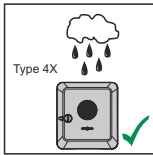

The inverter is suitable for outdoor installation.

When properly installed, the inverter has a Type 4X protection class, is not susceptible to spraying water on any side and can also be operated in moist environments.

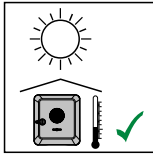
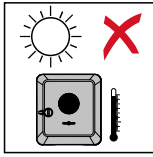

In order to keep inverter heating as low as possible, do not expose the inverter to direct sunlight. The inverter should be installed in a protected location, e.g., near the PV modules or under an overhanging roof.

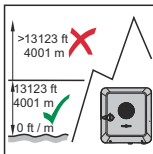

**IMPORTANT!** The inverter must not be installed or operated at more than 13,123 ft / 4001 m above sea level.

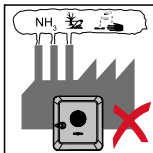

Do not install the inverter:

- Where it may be exposed to ammonia, corrosive gases, acids or salts (e.g., fertilizer storage areas, vent openings for livestock stables, chemical plants, tanneries, etc.)

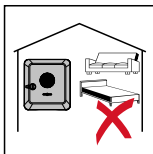

During certain operating phases the inverter may produce a slight noise. For this reason it should not be installed in an occupied living area.

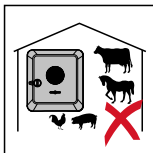

Do not install the inverter in:

- Areas where there is an increased risk of accidents from farm animals (horses, cattle, sheep, pigs, etc.)
- Stables or adjoining areas
- Storage areas for hay, straw, chaff, animal feed, fertilizers, etc.

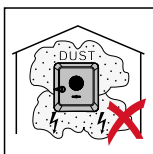

The inverter is essentially designed to be dustproof (Type 4X). In areas of high dust accumulation, dust deposits may collect on the cooling surfaces, and thus impair the thermal performance. Regular cleaning is required in this case; see the chapter headed **Operation in dusty environments** on page 100. We therefore recommend not installing the inverter in areas and environments with high dust accumulation.

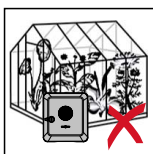

Do not install the inverter in:

- Greenhouses
- Storage or processing areas for fruit, vegetables or viticulture products
- Areas used in the preparation of grain, green fodder or animal feeds

**Installation position of the inverter**

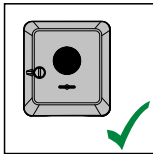

The inverter is suitable for vertical installation on a vertical wall or column.

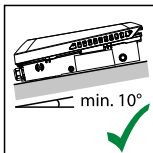
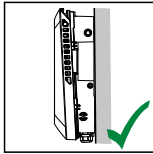

The inverter is suitable for installation on a sloping surface (min. slope of underside 10°).

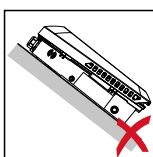

Do not install the inverter on a sloping surface with the connections upwards.

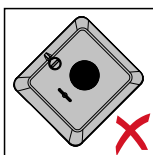

Do not install the inverter in a sloping position on a vertical wall or column.

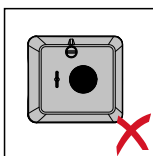

Do not install the inverter in a horizontal position on a vertical wall or column.

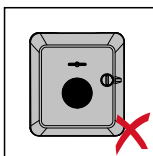

Do not install the inverter with the connections upwards on a vertical wall or column.

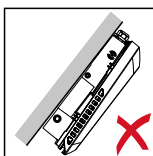
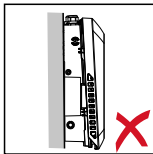

Do not install the inverter overhanging with the connections upwards.

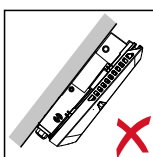

Do not install the inverter overhanging with the connections downwards.

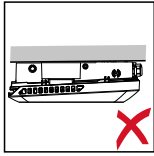

Do not install the inverter on the ceiling.

# Knockouts

## Preparing knockouts for connection

**IMPORTANT!** The knockouts must be drilled out using a step drill bit only. The maximum conduit sizes are ½ - 1 inch / 13 - 25 mm.

**IMPORTANT!** Void warranty if the conduit holes are drilled improperly.

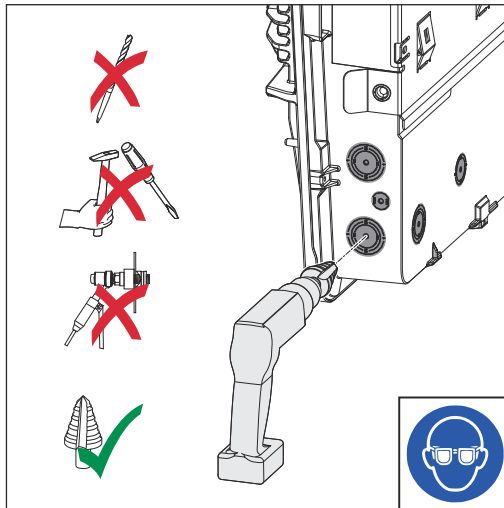

- Use suitable eye protection when drilling out the knockouts.
- Avoid drilling too far to ensure the connection area is not damaged.
- When drilling out the knockouts at the back, place the inverter on an even surface with the back upwards so that shavings and pieces of plastic can fall out of the inverter.
- If necessary, deburr the knockouts with a suitable tool and remove the drilling residues from the inverter.

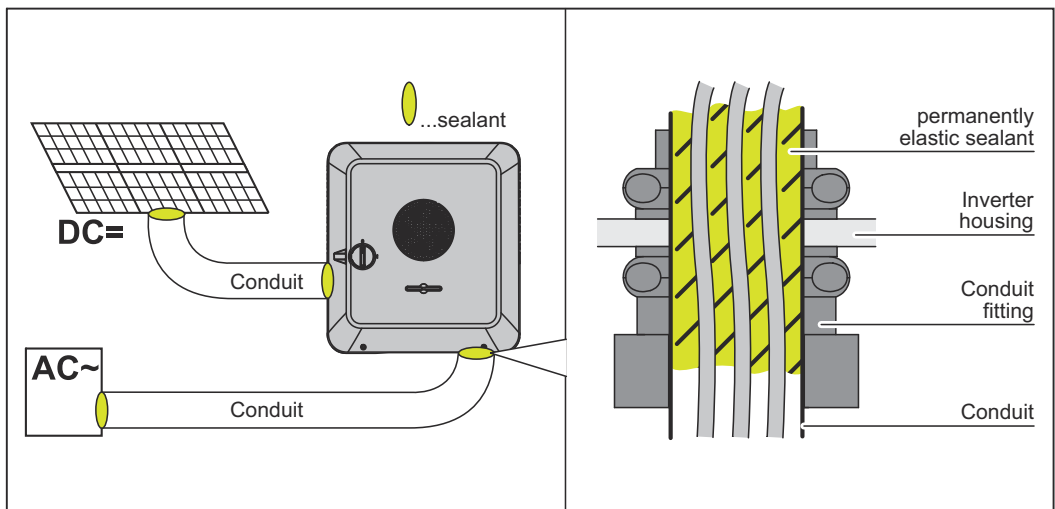

### NOTE!

**Condensation within the conduits can damage the inverter or components of the photovoltaic systems.**

To avoid undesirable air circulation and condensation in the conduits:

- ▶ Attach appropriate conduits to all knockouts that have been drilled open.
- ▶ When installing outdoors, only use waterproof conduit fittings and conduits.
- ▶ Seal the conduits in accordance with the pictures above on both sides.

### NOTE!

**Conduit fittings and conduits are not part of the scope of supply for the inverter.**

# Installing the mounting bracket and attaching the inverter

---

## Selecting the mounting material

Use the corresponding fixing materials depending on the subsurface and observe the screw dimension recommendations for the mounting bracket. The installer is responsible for selecting the right type of fixing.

---

## Properties of the mounting bracket

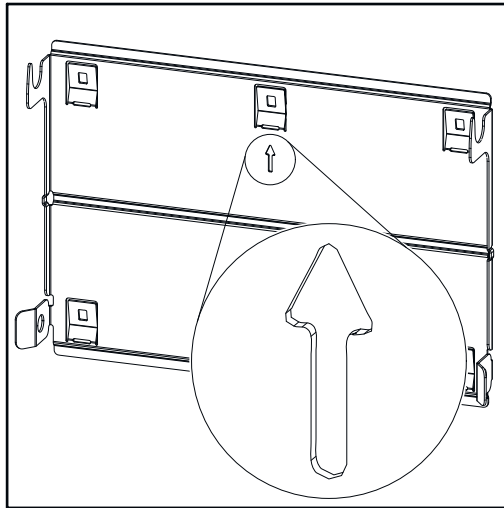

The mounting bracket (illustration) can also be used as a guide.

The pre-drilled holes on the mounting bracket are intended for screws with a thread diameter of 0.24 - 0.32 inches. The distance from the left to the right pre-drilled hole is 12 inches.

Unevenness on the mounting surface (e.g. coarse-textured plaster) is largely compensated by the mounting bracket.

---

## Do not deform the mounting bracket

### NOTE!

**When attaching the mounting bracket to the wall or to a column, make sure that the mounting bracket is not deformed.**

A deformed mounting bracket may make it difficult to clip/swivel the inverter into position.

---

## Fitting the mounting bracket to a wall

### IMPORTANT!

When installing the mounting bracket, make sure that it is installed with the arrow pointing upwards.

---

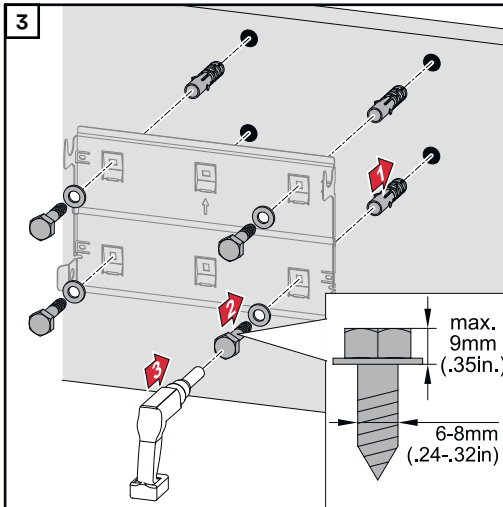
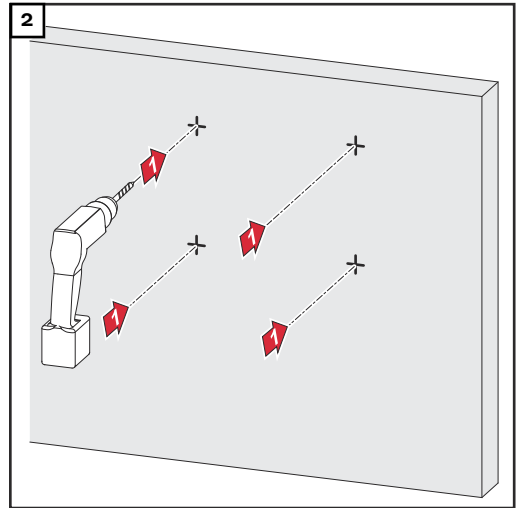
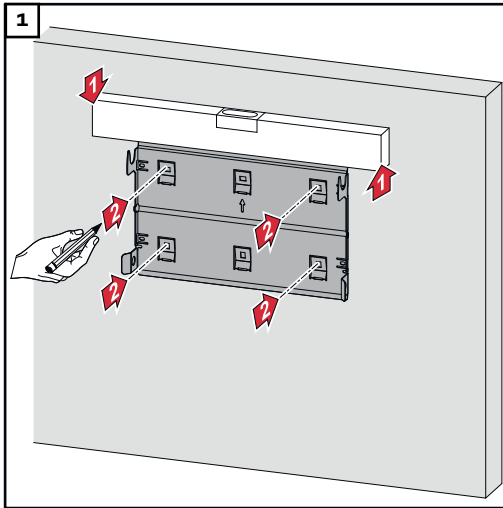

**Installing the mounting bracket on a mast or beam**

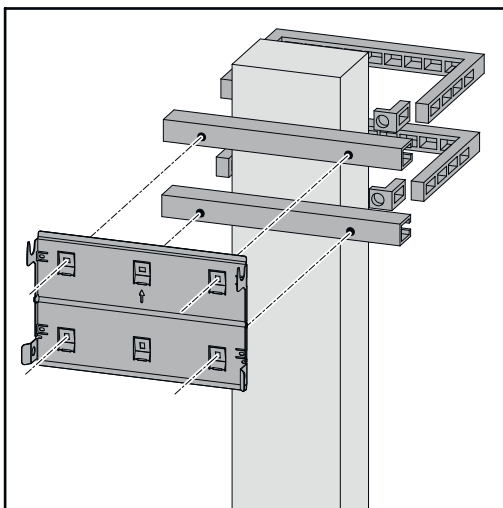

When installing the inverter on a mast or beam, Fronius recommends using the "Pole clamp" (order no. SZ 2584.000) mounting kit from Rittal GmbH.

The "Pole clamp" kit covers the following dimensions:

- Rectangular mast or beam with a side length of 1.97 - 5.91 inches
- Round mast or beam with a diameter of 1.57 - 7.48 inches

**Attaching the mounting bracket to mounting rails**

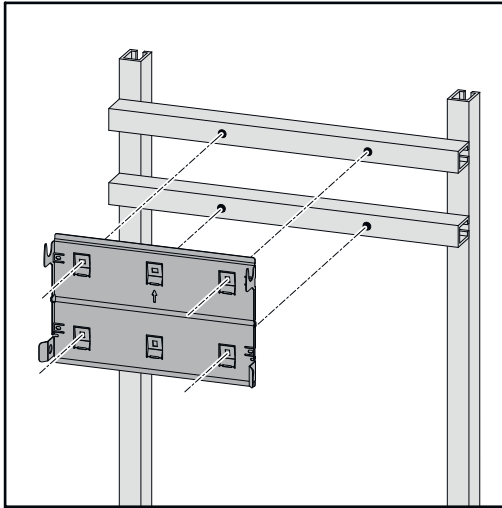

**IMPORTANT!**

The mounting bracket must be affixed at a minimum of four points.

**Attaching the inverter to the mounting bracket**

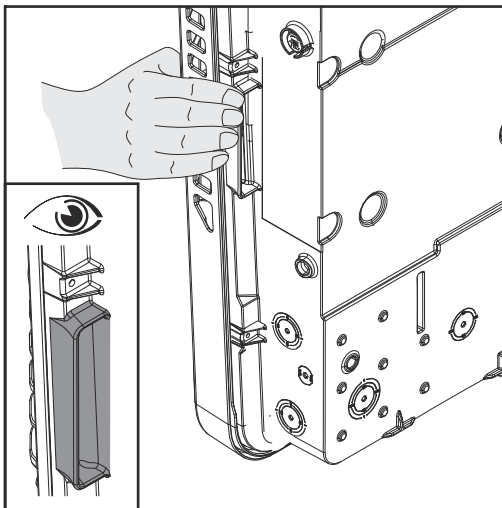

Integrated grips, which facilitate lifting/clipping, are located on the side of the inverter.

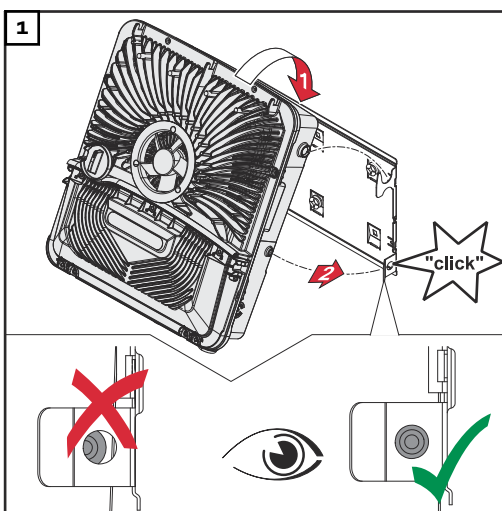

Clip the inverter into the mounting bracket from above. The connections must point downwards.

The lower area of the inverter is pushed into the snap-in tabs until the inverter engages on both sides with an audible click.

Ensure the correct position of the inverter on both sides.



# Requirements for connecting the inverter

## Various cable types

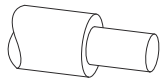
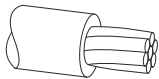
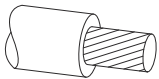
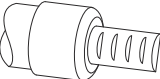
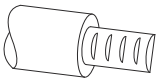

| Solid   | Multi-stranded  | Fine-stranded   | Fine-stranded with ferule and collar  | Fine-stranded with ferule without collar  |
|---|---|---|---|---|
|  |  |  |  |  |

## Permitted cables for the electrical connection

"Round copper conductors can be connected to the terminals of the inverter as described below":

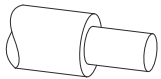
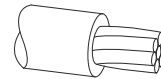
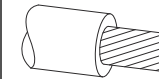
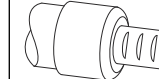
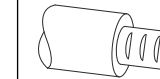
- Copper: round, solid
- Copper: round, fine-stranded

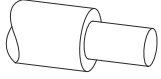
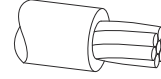
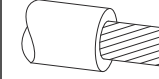
| Grid connections with push-in terminal*  |  |  |  |  |  |
|--|--|--|--|--|--|
| Select a sufficiently large cable cross-section based on the actual device output. |  |  |  |  |  |
| Number of pins   |  |  |  |  |  |
| 4  | AWG 12-6 / 4<br>- 16 mm <sup>2</sup>   | AWG 12-6 / 4<br>- 16 mm <sup>2</sup>   | AWG 12-6 / 4<br>- 16 mm <sup>2</sup>   | AWG 12-6 / 4<br>- 16 mm <sup>2</sup>   | AWG 12-6 / 4<br>- 16 mm <sup>2</sup>   |

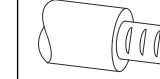
| Grid connections for backup power with push-in terminal*                           |   |   |   |   |   |
|--|---|---|---|---|---|
| Select a sufficiently large cable cross-section based on the actual device output. |   |   |   |   |   |
| Number of pins   |  |  |  |  |  |
| 3  | AWG 16-8 /<br>1.5 - 10 mm <sup>2</sup>  | AWG 16-8 /<br>1.5 - 10 mm <sup>2</sup>  | AWG 16-8 /<br>1.5 - 10 mm <sup>2</sup>  | AWG 16-8 /<br>1.5 - 10 mm <sup>2</sup>  | AWG 16-8 /<br>1.5 - 10 mm <sup>2</sup>  |

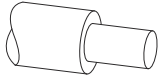
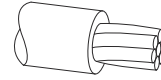
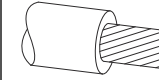
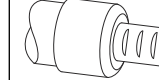
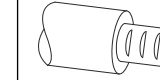
| PV connections with push-in terminal   |   |   |   |   |   |
|--|---|---|---|---|---|
| Select a sufficiently large cable cross-section based on the actual device output. |   |   |   |   |   |
| Number of pins   |  |  |  |  |  |
| 2 x 5  | AWG 14-8 /<br>2.5 - 10 mm <sup>2</sup>  | AWG 14-8 /<br>2.5 - 10 mm <sup>2</sup>  | AWG 14-8 /<br>2.5 - 10 mm <sup>2</sup>  | AWG 14-8 /<br>2.5 - 10 mm <sup>2</sup>  | AWG 14-8 /<br>2.5 - 10 mm <sup>2</sup>  |

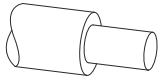
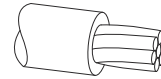
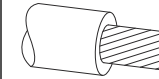
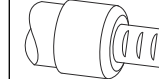
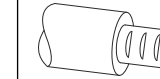
| Ground electrode terminal (6-pin)  |   |   |   |   |   |
|--|---|---|---|---|---|
| Select a sufficiently large cable cross-section based on the actual device output. |   |   |   |   |   |
| Number of pins   |  |  |  |  |  |

| Ground electrode terminal (6-pin)  |  |  |  |  |  |
|--|--|--|--|--|--|
| Select a sufficiently large cable cross-section based on the actual device output. |  |  |  |  |  |
| 2  | AWG 14-6 /<br>2.5 - 16 mm <sup>2</sup> | AWG 14-6 /<br>2.5 - 16 mm <sup>2</sup> | AWG 14-6 /<br>2.5 - 16 mm <sup>2</sup> | AWG 14-6 /<br>2.5 - 16 mm <sup>2</sup> | AWG 14-6 /<br>2.5 - 16 mm <sup>2</sup> |
| 4  | AWG 14-8 /<br>2.5 - 10 mm <sup>2</sup> | AWG 14-8 /<br>2.5 - 10 mm <sup>2</sup> | AWG 14-8 /<br>2.5 - 10 mm <sup>2</sup> | AWG 14-8 /<br>2.5 - 10 mm <sup>2</sup> | AWG 14-8 /<br>2.5 - 10 mm <sup>2</sup> |

\* According to product standards UL1741 3rd Edition, Table 20.1 and CSA-C22.2 No.107.1-16

### Cable diameter for push-in terminals

Cable diameter for connection to the push-in terminal: 0.27 inches

#### IMPORTANT

For double-insulated cables with a cable diameter above 0.27 inches, the outer layer of insulation must be removed for the connection to the push-in terminal.

### Permitted cables for the data communication connection



Cables with the following design can be connected to the terminals of the inverter:

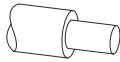
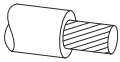
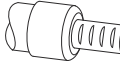
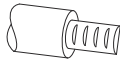

- Copper: round, solid
- Copper: round, fine-stranded

#### IMPORTANT!

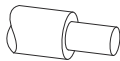
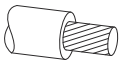
If several single conductors are connected to an input of the push-in terminals, connect the single conductors with a corresponding ferrule.

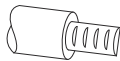
| WSD connections with push-in terminal |                     |   |   |   |   |  |
|---------------------------------------|---------------------|---|---|---|---|--|
| Distance max.                         | Strip-ping length   |  |  |  |  | Cable recommendation                     |
| 109 yd / 100 m                        | 0.39 inches / 10 mm | AWG 26-16   | AWG 26-16   | AWG 26-18   | AWG 26-16   | min. CAT 5 UTP (unshielded twisted pair) |

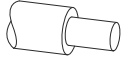
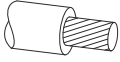
| Modbus connections with push-in terminal |                     |   |   |   |   |  |
|--|---------------------|---|---|---|---|--|
| Distance max.                            | Strip-ping length   |  |  |  |  | Cable recommendation                   |
| 328 yd / 300 m                           | 0.39 inches / 10 mm | AWG 26-16   | AWG 26-16   | AWG 26-18   | AWG 26-16   | min. CAT 5 STP (shielded twisted pair) |

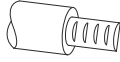
| IO connections with push-in terminal |                            |   |   |   |   |                                    |
|--------------------------------------|----------------------------|---|---|---|---|------------------------------------|
| Dis-<br>tance<br>max.                | Strip-<br>ping<br>length   |  |  |  |  | Cable re-<br>commenda-<br>tion     |
| 32 yd /<br>29 m                      | 0.39 inch<br>es / 10<br>mm | AWG 26–16   | AWG 26–16   | AWG 26–18   | AWG 26–16   | Single con-<br>ductors<br>possible |

| LAN connections  |
|--|
| Fronius recommends using at least CAT 5 STP (shielded twisted pair) cables and a maximum distance of 109 yd / 100 m. |

**Maximum altern-  
ating current  
fuse protection**

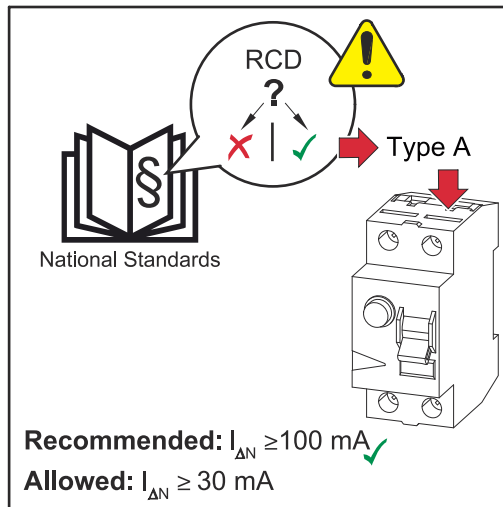

**NOTE!**

The national regulations of the grid operator or other factors may require a residual current circuit breaker in the AC connection lead.

For this situation, a type A residual current circuit breaker is generally adequate. Nevertheless, false alarms can be triggered for the type A residual-current circuit breaker in individual cases and depending on local conditions. For this reason, in accordance with national legislation, Fronius recommends that a residual-current circuit breaker with a tripping current of at least 100 mA suitable for frequency converters be used.

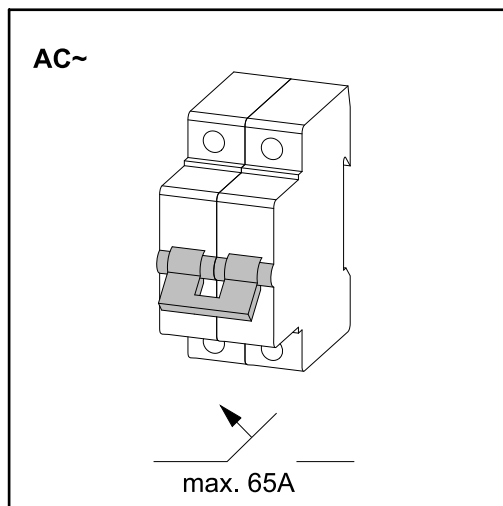

**IMPORTANT!**

The inverter can be fused with max. an automatic circuit breaker 65 A.

| Inverter                        | Phases | Maximum fuse rating | Recommended fuse rating ( 208V / 220V / 240 V ) |
|---------------------------------|--------|---------------------|---|
| Fronius Primo GEN24 7.7 208-240 | 1      | 65 A                | 50 A / 45 A / 40 A                              |

| Inverter                            | Phases | Maximum fuse rating | Recommended fuse rating ( 208V / 220V / 240 V) |
|-------------------------------------|--------|---------------------|--|
| Fronius Primo GEN24 10.0<br>208-240 | 1      | 65 A                | 60 A / 60 A / 55 A                             |

# Connecting the inverter to the public grid (AC side)

## Safety

### WARNING!

#### **Danger from incorrect operation and work that is not carried out properly.**

This can result in severe personal injury and damage to property.

- ▶ Read the Installation Instructions and Operating Instructions before installing and commissioning the equipment.
- ▶ Only qualified personnel are authorized to commission the inverter and only within the scope of the respective technical regulations.

### WARNING!

#### **Danger from grid voltage and DC voltage from PV modules that are exposed to light.**

An electric shock can be fatal.

- ▶ Prior to any connection work, ensure that the inverter is de-energized on the AC side and the DC side.
- ▶ Only qualified personnel may connect this equipment to the public grid

### WARNING!

#### **Danger from damaged and/or contaminated terminals.**

This can result in severe personal injury and damage to property.

- ▶ Prior to connection work, check the terminals for damage and contamination.
- ▶ Remove any contamination while the equipment is de-energized.
- ▶ Have defective terminals replaced by an authorized technician.

## Suitable grids

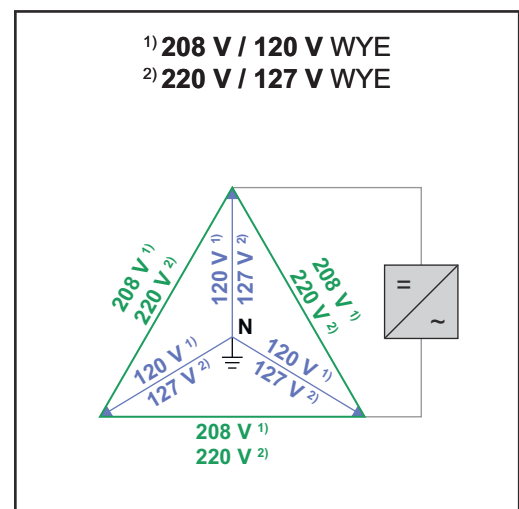
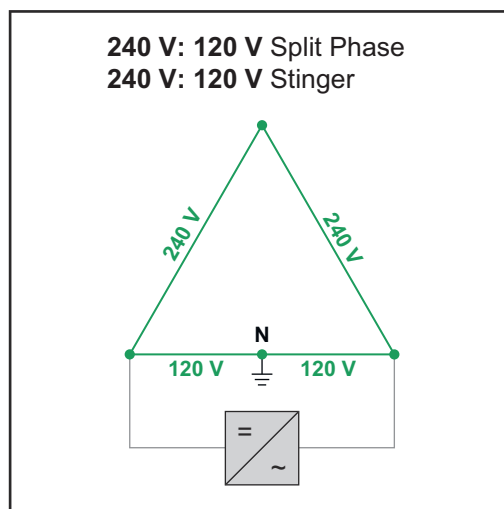

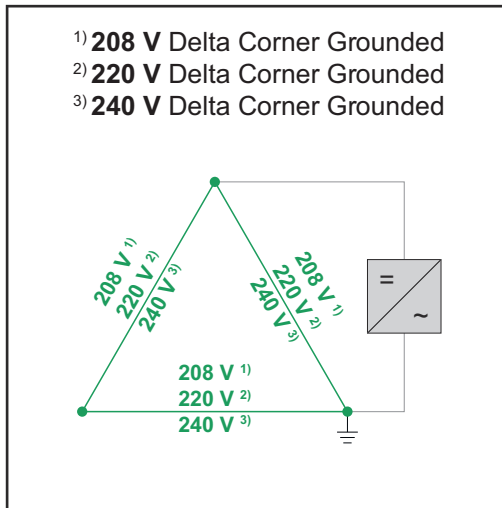

**Connecting the inverter to the public grid (AC side)**

**NOTE!**

**In grid configurations with neutral conductors, the neutral conductor must be connected in order to operate the inverter.**

It is not possible to operate the inverter in ungrounded grids, e.g., IT grids (insulated grids without ground conductor). The grid power feed operation of the inverter can be adversely affected by an insufficiently dimensioned neutral conductor.

- ▶ Make sure that the grid's neutral conductor is grounded.
- ▶ Ensure the neutral conductor and live conductor are the same size.

**IMPORTANT!** The ground conductor/grounding of the AC cable must be laid so that it is disconnected last in the event of a failure of the strain-relief device. Ensure the ground conductor/grounding is longer and in a loop.

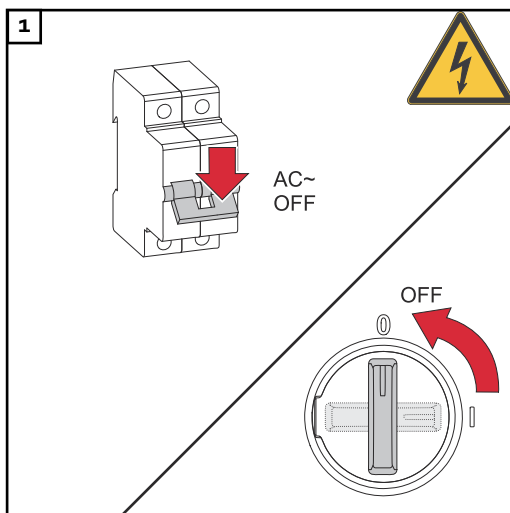

Turn off the automatic circuit breaker. Set the DC disconnect to the "Off" switch position.

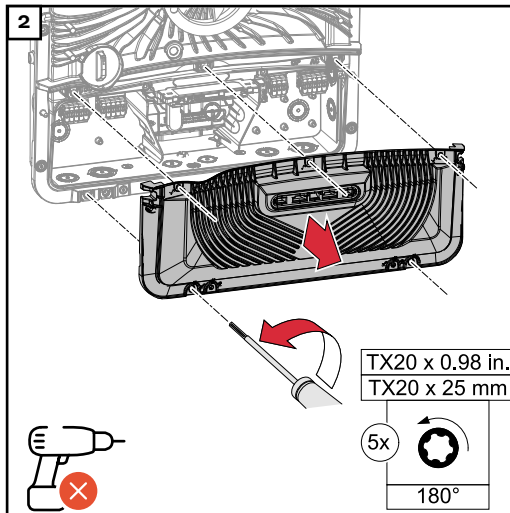

Loosen the five screws of the connection area cover by rotating them 180° to the left using a screwdriver (TX20). Remove the connection area cover from the device.

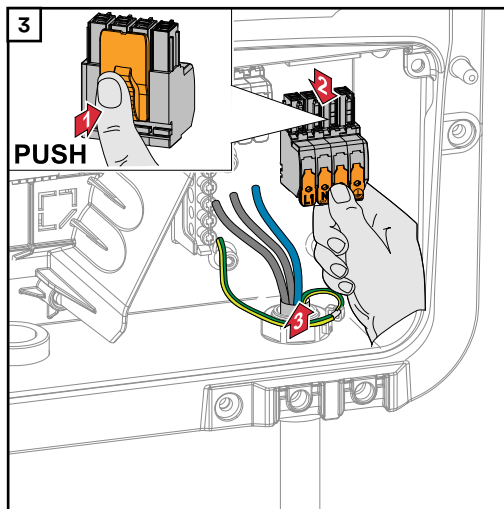

Guide the mains cable from below through the electrical installation tube on the right side. Remove the AC terminal.

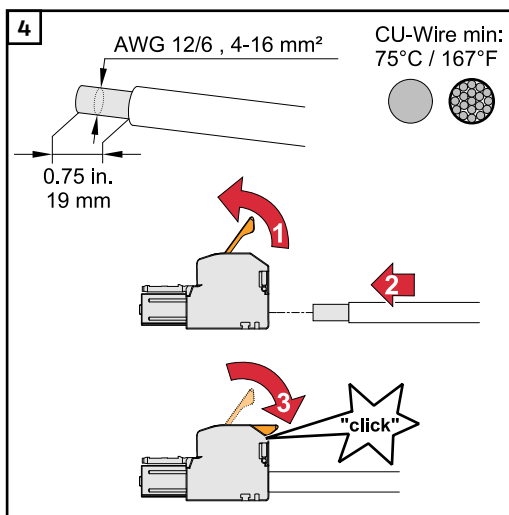

Strip the insulation of the single conductors by 0.47 inches. The cable cross-section must be selected in accordance with the instructions in [Permitted cables for the electrical connection](#) from page 45.

Lift to open the terminal's operating lever and insert the stripped single conductor into the slot provided as far as it will go.

Then close the terminal's operating lever until it engages.

**NOTE!**

**Only one conductor may be connected to each pin.**

The AC cables can be connected to the AC terminals without ferrules.

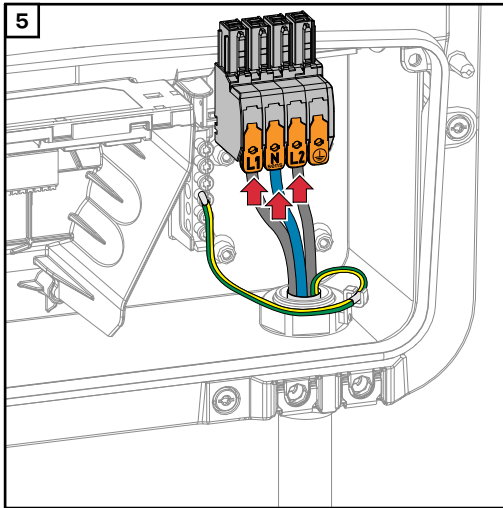

- L1 Phase conductor
- Nsens Neutral conductor\*
- L2 Phase conductor

\* Valid for grid configurations with neutral conductors.

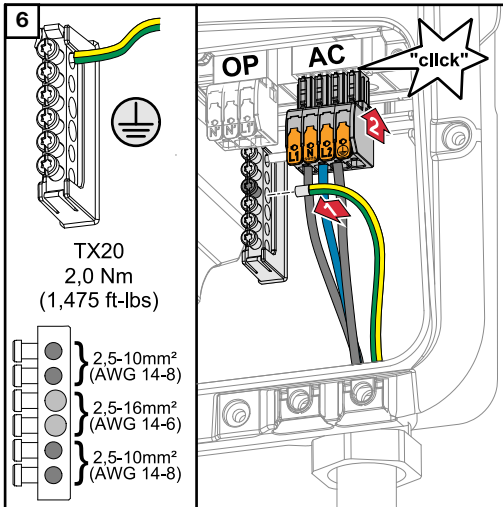

Fasten the grounding cable to the ground electrode terminal using a screwdriver (TX20) and a torque of 1.475 ft lbs / 2 Nm. Insert the AC terminal into the AC slot until it engages.



# Connecting solar module strings to the inverter

## General information about PV modules

To enable suitable PV modules to be chosen and to use the inverter as efficiently as possible, it is important to bear the following points in mind:

- If insolation is constant and the temperature is falling, the open-circuit voltage of the PV modules will increase. The open-circuit voltage must not exceed the max. permissible system voltage. An open-circuit voltage above the indicated values will damage the inverter, and all warranty rights will become null and void.
- The temperature coefficients on the data sheet of the PV modules must be observed.
- Exact values for sizing the PV modules can be obtained using suitable calculation tools, such as the [Fronius Solar.creator](#).

### IMPORTANT!

Before connecting up the PV modules, check that the voltage for the PV modules specified by the manufacturer corresponds to the actual measured voltage.

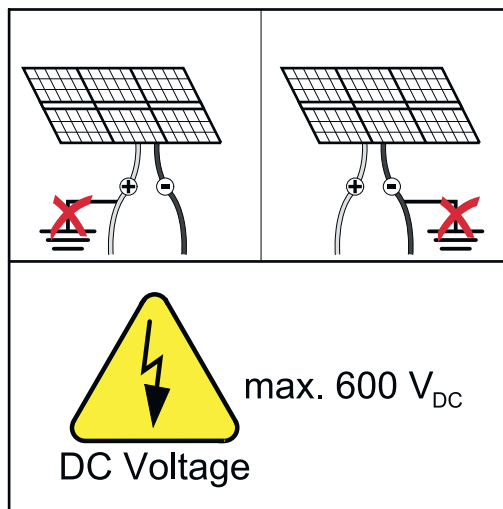

### IMPORTANT!

Solar module strings must not be grounded.

## Safety

### **WARNING!**

#### **Danger from incorrect operation and work that is not carried out properly.**

This can result in severe personal injury and damage to property.

- ▶ The commissioning, maintenance, and service work in the inverter's power stage set may only be carried out by Fronius-trained service personnel in accordance with the technical specifications.
- ▶ Read the Installation Instructions and Operating Instructions before installing and commissioning the equipment.

**⚠ WARNING!**

**Danger from grid voltage and DC voltage from PV modules that are exposed to light.**

This can result in severe personal injury and damage to property.

- ▶ All connection, maintenance, and service work should only be carried out when the AC and DC sides have been disconnected from the inverter and are de-energized.
- ▶ Only an authorized electrical engineer is permitted to connect this equipment to the public grid.

**⚠ WARNING!**

**Danger from damaged and/or contaminated terminals.**

This can result in severe personal injury and damage to property.

- ▶ Prior to connection work, check the terminals for damage and contamination.
- ▶ Remove any contamination while the equipment is de-energized.
- ▶ Have defective terminals replaced by an authorized specialist.

**PV generator, general**

Two independent PV inputs (PV 1 and PV 2) are available. These inputs can be connected to a number of different modules.

When starting for the first time, set up the PV generator in accordance with the respective configuration (can also be carried out at a later date in the "**System configuration**" menu field under menu item "**Components**").

**Module array configuration 7.7 - 10.0 kW**

**IMPORTANT!**

The installation must be carried out in accordance with the nationally applicable standards and directives.

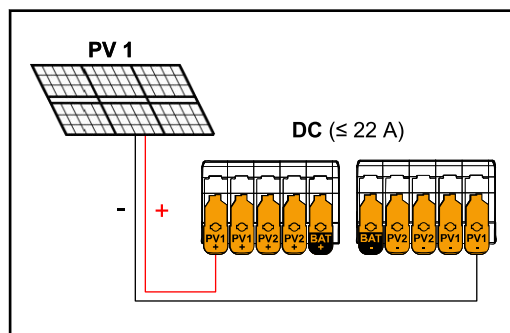

**Module array settings:**

PV 1: **ON**  
PV 2: **OFF**

**IMPORTANT!**

The maximum current load of a single terminal is 22 A.

Current equal to or less than 22 A ( $I_{dcmax}$ ).

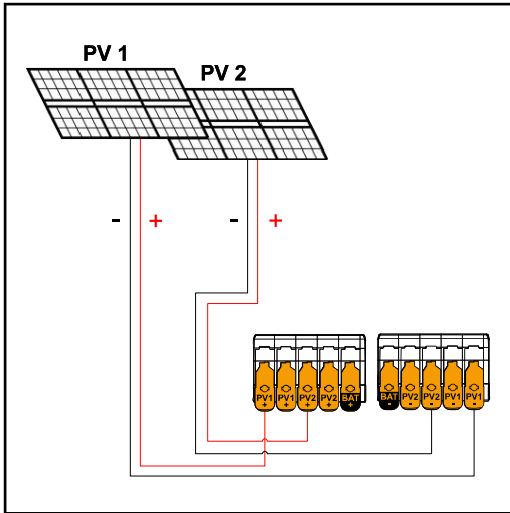

**Module array settings:**

PV 1: **ON**

PV 2: **ON**

*PV 1 less than or equal to 41.25 A (I<sub>SC</sub> PV1)  
 PV 2 less than or equal to 36 A (I<sub>SC</sub> PV2)*

**Connecting solar module strings to the inverter**

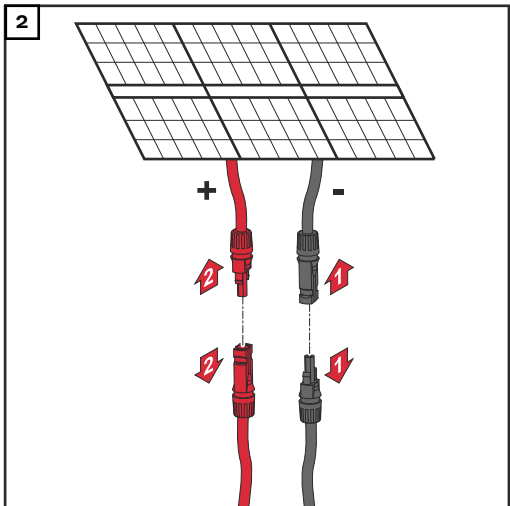
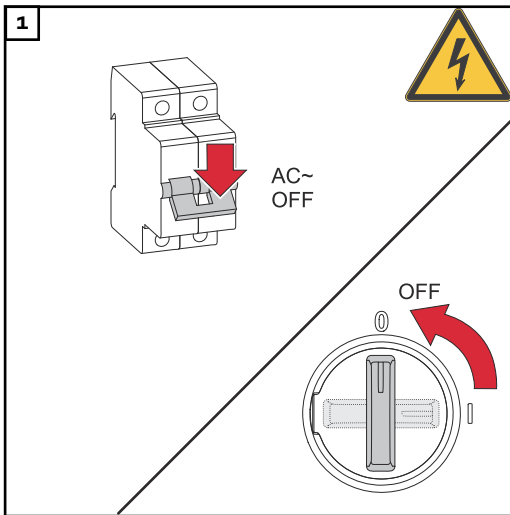

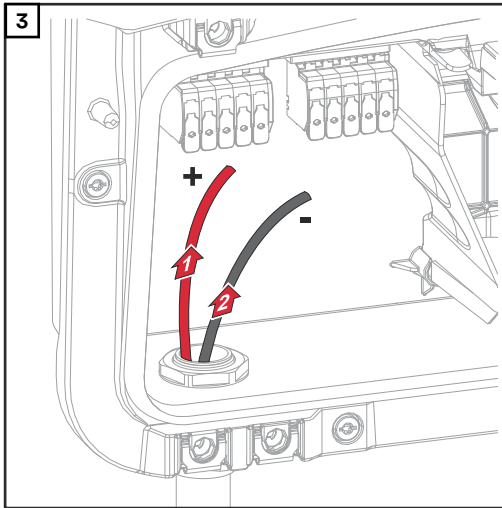

Guide the DC cables through the electrical installation tube.

**IMPORTANT!**

Guide the cables through the electrical installation tube before stripping them in order to avoid twisting/bending single wires.

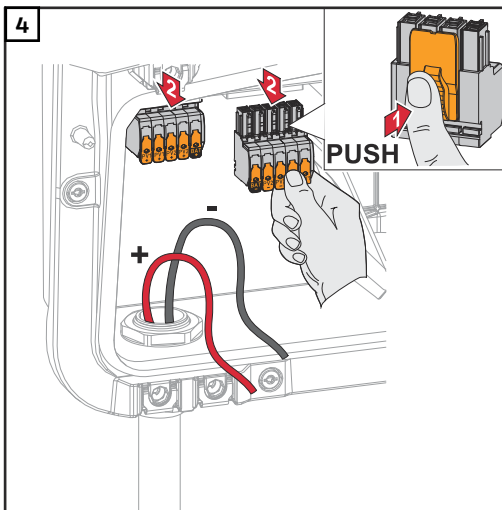

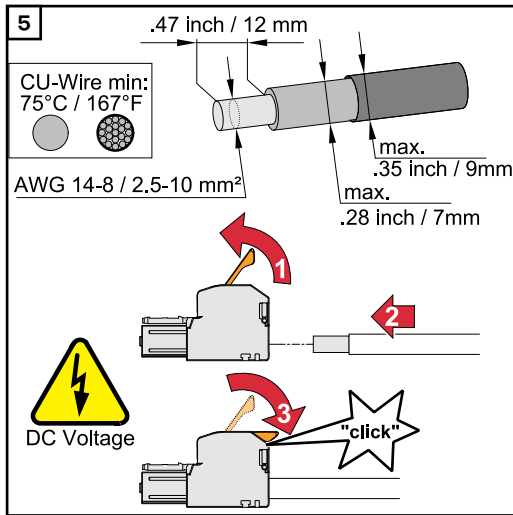

Select the cable cross-section in accordance with the instructions in **Permitted cables for the electrical connection** from page 45.

Strip the insulation of the single conductors by 0.47 inches. Lift to open the terminal's operating lever and insert the stripped single conductor into the slot provided in the terminal as far as it will go.

Then close the terminal's operating lever until it engages.

\* For double-insulated cables, observe the max. cross-section of the insulation.



### WARNING!

**Danger from loose and/or incorrectly clamped single conductors in the terminal.**

This can result in severe personal injury and damage to property.

- ▶ Only connect one single conductor at each slot provided in the terminal.
- ▶ Check that the single conductors are secure in the terminal.
- ▶ Make sure that the single conductor has been fully inserted into the terminal and that no single wires are protruding out of the terminal.

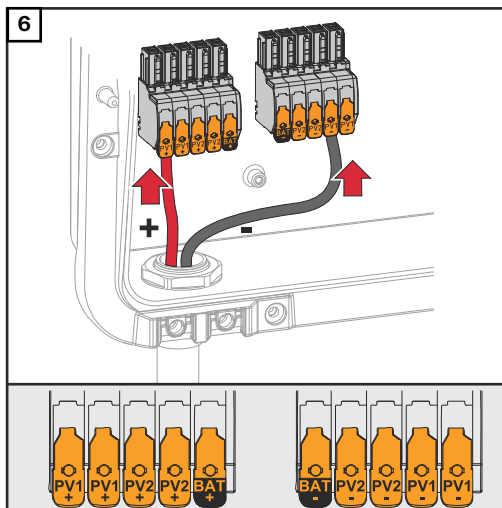

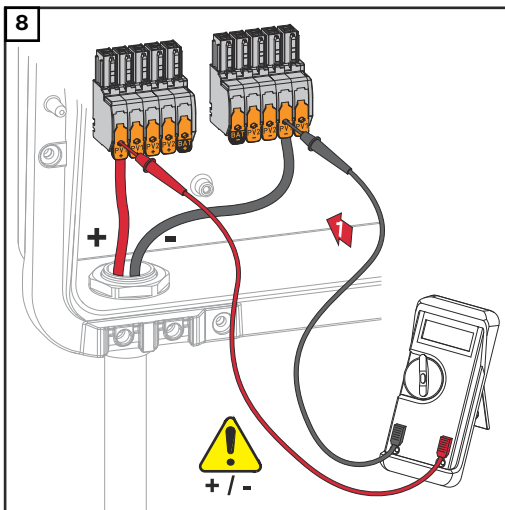
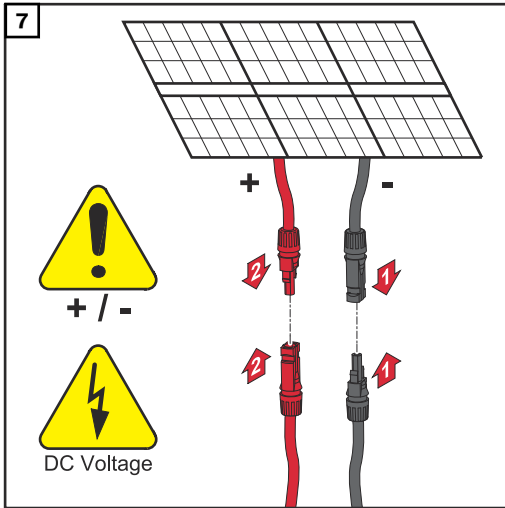

Use a suitable measuring instrument to check the voltage and polarity of the DC cabling. Remove both DC terminals from the slots.

**CAUTION!**

**Danger due to polarity reversal at the terminals.**

This may result in severe damage to the inverter.

- ▶ Use a suitable measuring instrument to check the polarity of the DC cabling.
- ▶ Use a suitable measuring instrument to check the voltage (**max. 600 V<sub>DC</sub>**)

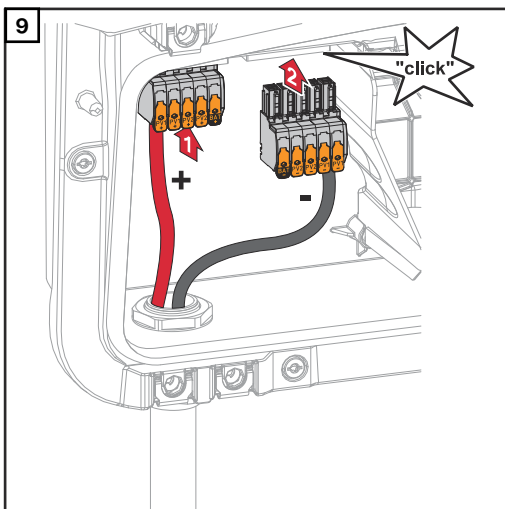

Insert the DC terminals into the respective slot until they engage.

# Connecting backup power - PV Point (OP)

---

## Safety

### **WARNING!**

#### **Danger from incorrect installation, commissioning, operation or incorrect use.**

This can result in severe personal injury and damage to property.

- ▶ Single 120 / 220 / 240 volt supply. Do not connect multi-wire branch circuits!
  - ▶ Only trained and qualified personnel are authorized to install and commission the system, and only within the scope of the technical regulations.
  - ▶ The Installation Instructions and Operating Instructions must be read carefully prior to use.
  - ▶ If anything is unclear, contact your vendor immediately.
- 

### **WARNING!**

#### **Danger from damaged and/or contaminated terminals.**

This can result in severe personal injury and damage to property.

- ▶ Prior to connection work, check the terminals for damage and contamination.
  - ▶ Remove any contamination while the equipment is de-energized.
  - ▶ Have defective terminals replaced by an authorized technician.
- 

### **WARNING!**

#### **Limited rapid shutdown function in backup power mode (PV Point and Full Backup)**

If PV Point or Full Backup is configured, rapid shutdown cannot be triggered via the loss of grid connection. This can result in serious personal injury and damage to the PV system.

- ▶ A WSD switch must be installed for all backup power modes (PV-Point and Full Backup) (see [Installing the WSD \(wired shutdown\)](#)). The rapid shutdown is then triggered via WSD.
- 

### **NOTE!**

#### **Power supply via the PV point is dependent on the available PV output**

If the PV modules are not supplying enough power, interruptions may occur.

- ▶ Do not connect any loads that require an interruption-free supply.
- 

### **IMPORTANT!**

The valid national laws, standards, and provisions, as well as the specifications of the relevant grid operator are to be taken into account and applied.

It is highly recommended that the specific installation be agreed with the grid operator and explicitly approved by this operator. This obligation applies to system constructors in particular (e.g., installers).

**NOTE!**

**All loads that are to be supplied via the OP terminal must be protected by means of a ground fault circuit interrupter.**

In order to ensure the ground fault circuit interrupter operates properly, a connection must be established between the neutral conductor N' (OP) and equipment grounding (GND).

Wiring proposal recommended by Fronius, see page 115.

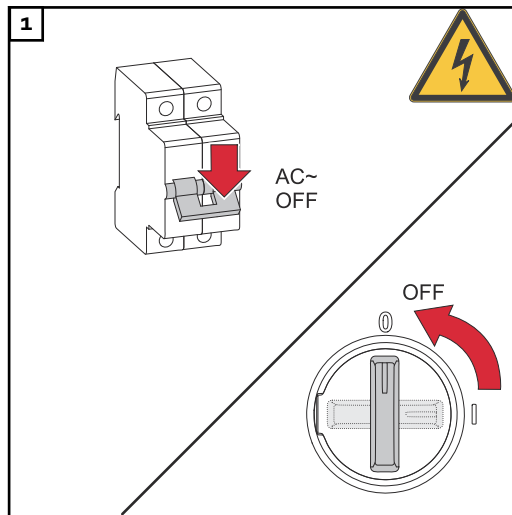

Turn off the automatic circuit breaker. Set the DC disconnect to the "Off" switch position.

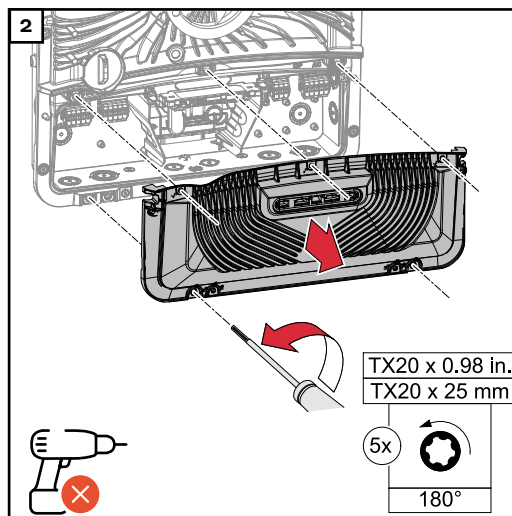

Loosen the five screws of the connection area cover by rotating them 180° to the left using a screwdriver (TX20). Remove the connection area cover from the device.

**⚠ CAUTION!**

**Danger from faulty or incorrect bores.**

This may lead to injuries to the eyes and hands as a result of flying debris and sharp edges, as well as damage to the inverter.

- ▶ When drilling, wear suitable protective goggles.
- ▶ Only use a step drill when drilling.
- ▶ Ensure that nothing on the inside of the device is damaged (e.g., the connection block).
- ▶ Adapt the diameter of the bore to match the corresponding connection.
- ▶ Deburr the bores using a suitable tool.
- ▶ Remove the drilling residues from the inverter.



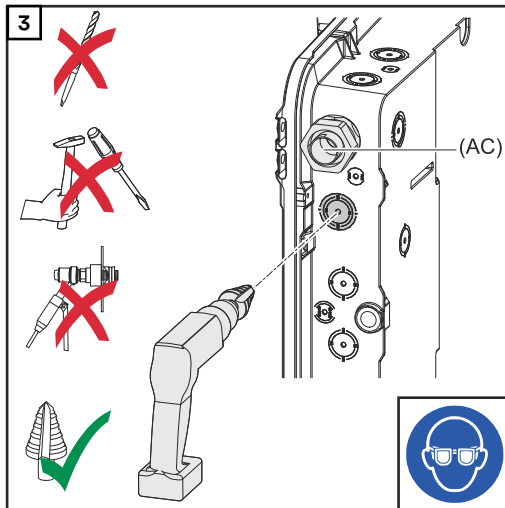

Drill out the knockout with a step drill.

**4** Insert the conduit into the knockout and fasten it using the torque specified by the manufacturer. Seal the conduit as per the chapter headed **Preparing knockouts for connection** on page **41**.

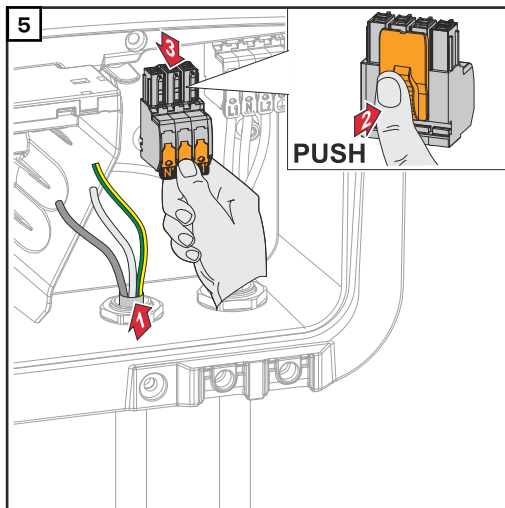

Guide the mains cable through the conduit from below. Remove the OP terminal.

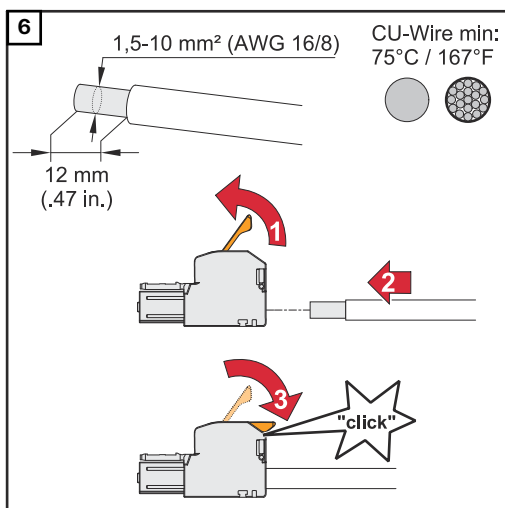

Strip the insulation of the single conductors by 0.47 inches / 12 mm. The cable cross-section must be between AWG 16 and AWG 8. Lift to open the terminal's operating lever and insert the stripped single conductor into the slot provided, all the way up to the stop. Then close the operating lever until it engages.

**NOTE!**

**Only one conductor may be connected to each pin. The lines can be connected without ferrules.**

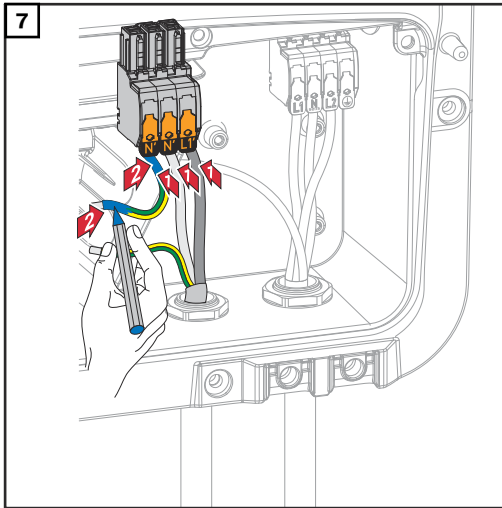

L1' Phase conductor  
 N' Neutral conductor  
 N' Ground conductor

**NOTE!**

The ground conductor must be produced with ends that are permanently marked blue, according to the national provisions, and have a cross-section of AWG 6.

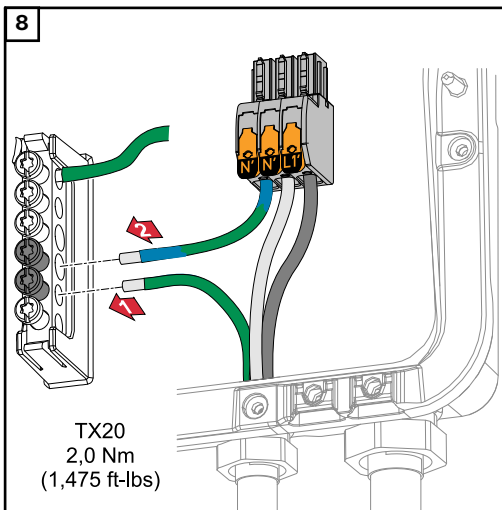

Fasten the ground conductor and PEN conductor to the ground electrode terminal using a screwdriver (TX20) and a torque of 1.47 ft-lbs / 2 Nm.

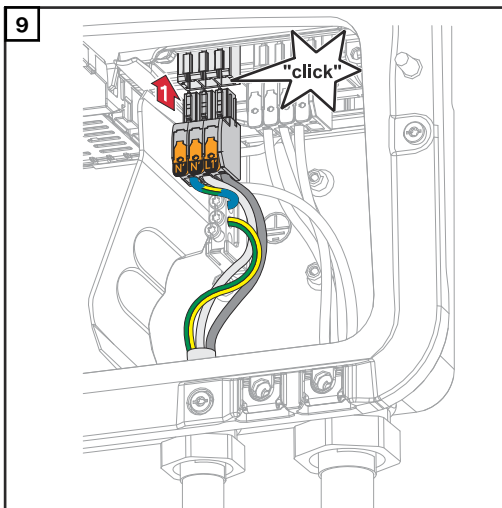

Insert the OP terminal into the OP slot until it engages.

# Connecting the data communication cables

## Modbus participants

The inputs M0 and M1 can be freely selected. A maximum of four Modbus participants can be connected to the Modbus terminal at inputs M0 and M1.

### IMPORTANT!

Only one primary meter can be connected to each inverter. If the **"Inverter Control via Modbus"** function is activated in the **"Communication" → "Modbus"** menu field, no Modbus participants are possible. It is not possible to send and receive data at the same time.

### Example 1:

| Input         | Number of primary meters | Number of secondary meters |
|---------------|--------------------------|----------------------------|
| Modbus 0 (M0) | 0                        | 4                          |
| Modbus 1 (M1) | 1                        | 3                          |

### Example 2:

| Input         | Number of primary meters | Number of secondary meters |
|---------------|--------------------------|----------------------------|
| Modbus 0 (M0) | 1                        | 3                          |
| Modbus 1 (M1) | 0                        | 4                          |

## Routing data communication cables

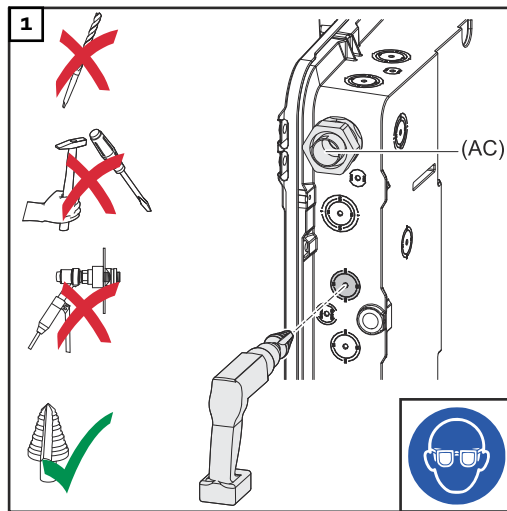

Drill out the knockout with a step drill.

- 2 Insert the conduit into the hole and fasten it using the torque specified by the manufacturer. Seal the conduit as per the chapter headed **Preparing knockouts for connection** on page 41.

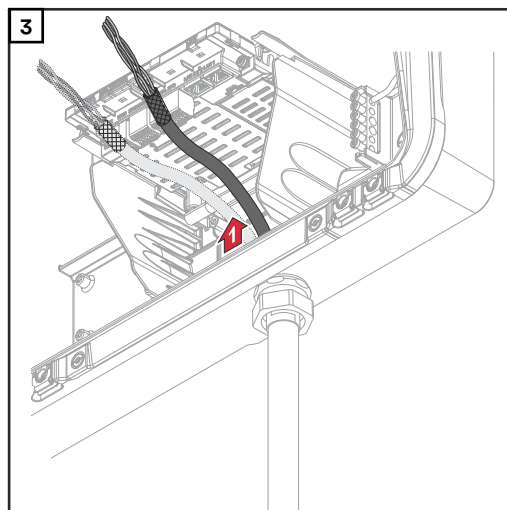

Run the data communication cables through the electrical installation tube from below.

## Terminating resistors

It may be possible for the system to function without terminating resistors. However, owing to interference, the use of terminating resistors according to the following overview is recommended for trouble-free operation.

For permissible cables and max. distances for the data communication area, refer to the chapter headed **Permitted cables for the data communication connection** on page 46.

**IMPORTANT!** Terminating resistors that are not positioned as illustrated can result in interference in the data communication.

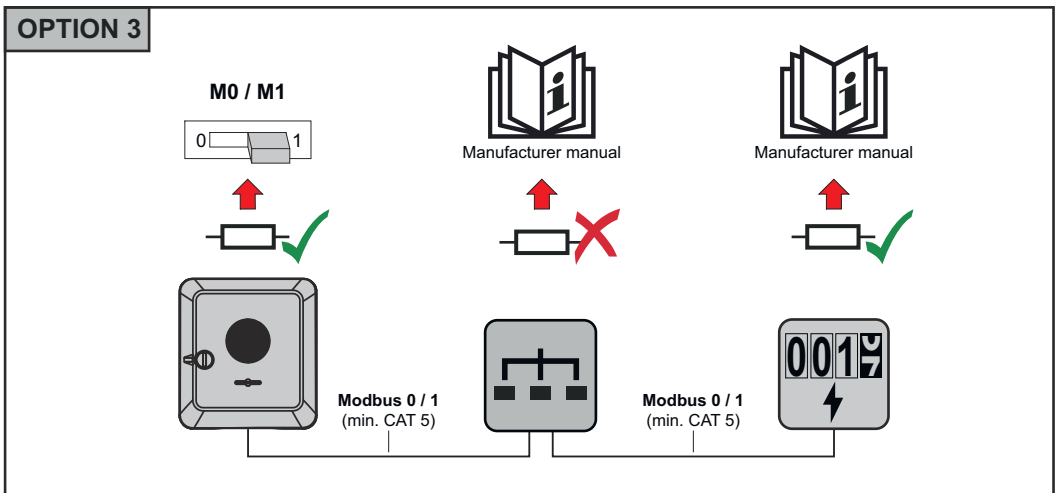
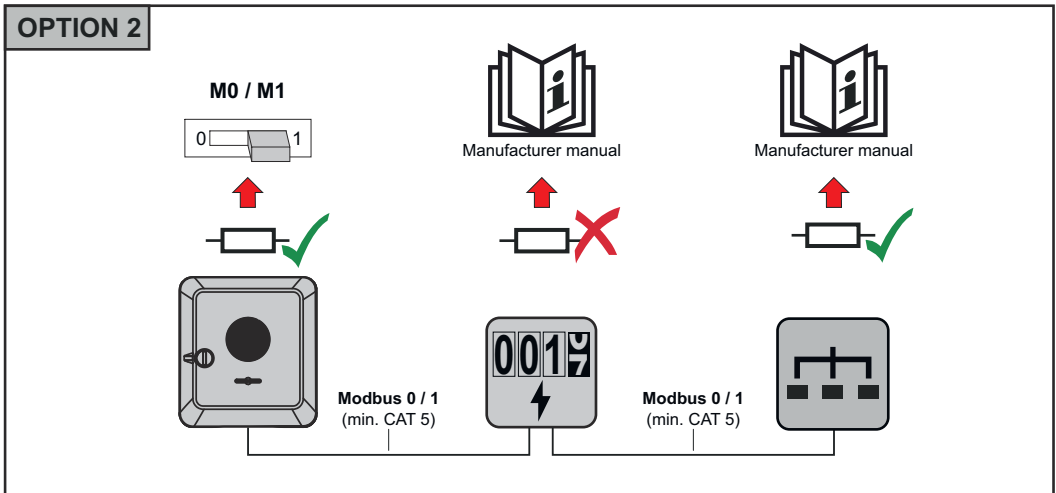
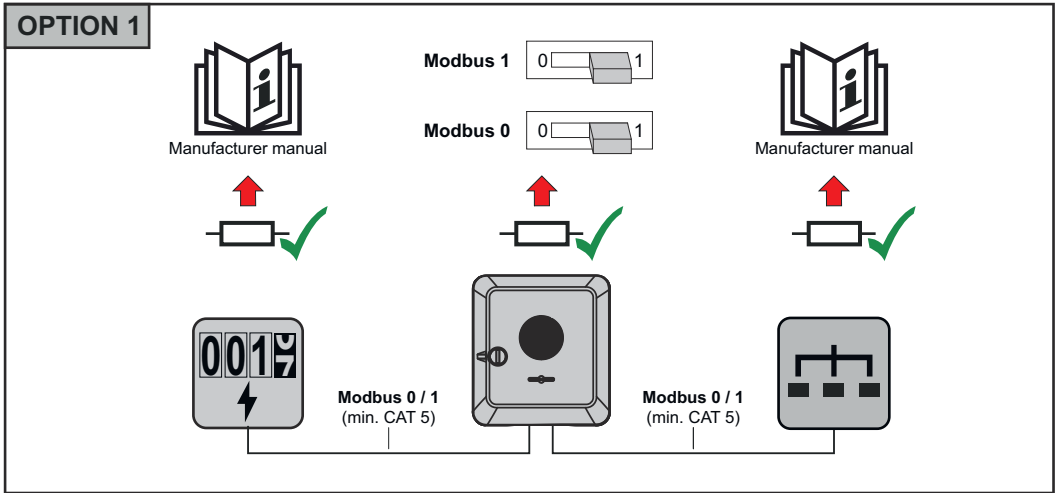

**Installing the WSD (wired shutdown)**

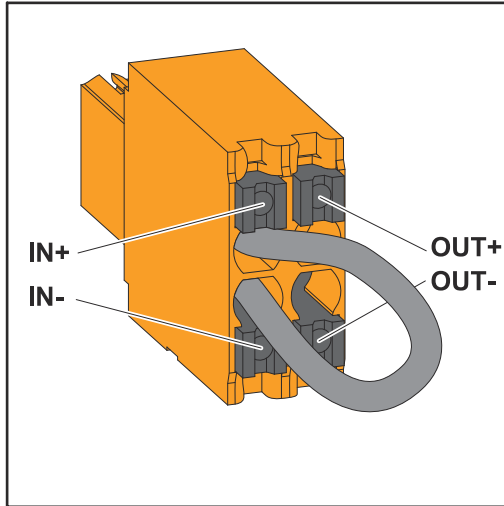

**⚠ WARNING!**

**Limited rapid shutdown function in backup power mode (PV Point and Full Backup)**

If PV Point or Full Backup is configured, rapid shutdown cannot be triggered via the loss of grid connection. This can result in serious personal injury and damage to the PV system.

- ▶ A WSD switch must be installed for all backup power modes (PV-Point and Full Backup) (see [Installing the WSD \(wired shutdown\)](#)). The rapid shutdown is then triggered via WSD.

**IMPORTANT!**

The push-in WSD terminal in the inverter's connection area is delivered with a bypass ex works as standard. The bypass must be removed when installing a trigger device or a WSD chain.

The WSD switch of the first inverter with connected trigger device in the WSD chain must be in position 1 (master). The WSD switch of all other inverters should be in position 0 (slave).

Max. distance between two devices: 109 yd / 100 m  
max. number of devices: 28

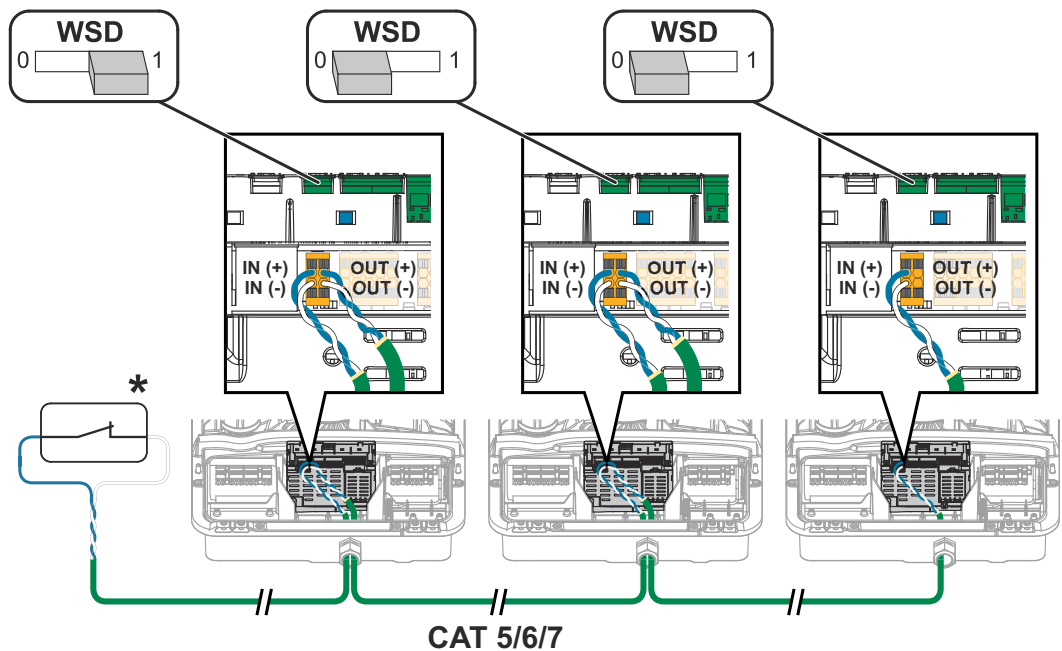

\* Floating contact of the trigger device (e.g., central grid and system protection). If several floating contacts are used in a WSD chain, these must be connected in series.

# Closing and commissioning the inverter

## Closing the inverter's connection area/housing cover, and commissioning

### NOTE!

The housing cover is fitted with a lock for safety reasons, which allows the housing cover on the inverter to be pivoted only when the DC disconnect is off.

- ▶ Only clip and pivot the housing cover into the inverter when the **DC disconnect is switched off**.
- ▶ Do not use excessive force to clip in and pivot the housing cover.

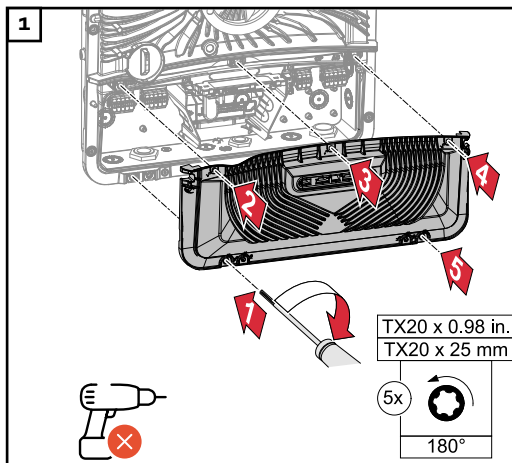

Place the cover on the connection area. Tighten the five screws by rotating them 180° to the right in the indicated order using a screwdriver (TX20).

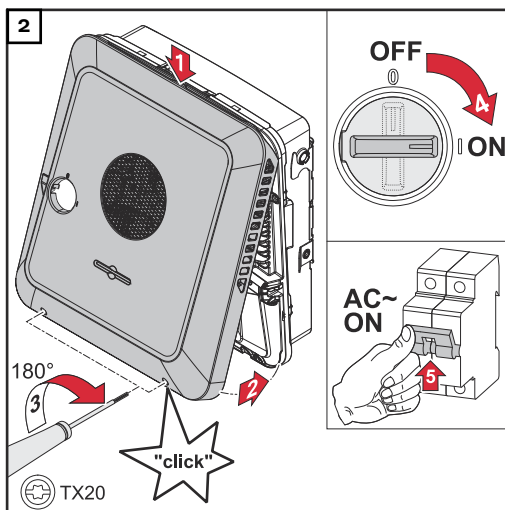

Clip the housing cover onto the inverter from above.

Press on the lower part of the housing cover and tighten the two screws 180° to the right using a Torx screwdriver (TX20).

Turn the DC disconnect to the "On" switch setting. Turn on the automatic circuit breaker.

**IMPORTANT!** Open the WLAN access point with the optical sensor; refer to the chapter headed **Button functions and LED status indicator** on page 26

## Starting the inverter for the first time

When starting the inverter for the first time, various setup settings must be configured.

If the setup is canceled before completion, the input data is not saved and the start screen with the installation wizard is shown once again. The data is saved in the event of an interruption, e.g., a power failure. Commissioning is continued at the point at which the interruption occurred after the power supply is restored. If the setup was interrupted, the inverter feeds energy into the grid at maximum 500 W and the operating status LED flashes yellow.

The country setup can only be set when starting the inverter for the first time. If the country setup needs to be changed at a later date, contact your installer/technical support.

## Installation with the app

The "Fronius Solar.start" app is required for installation. Depending on the mobile device used to perform the installation, the app is available on the relevant platform.

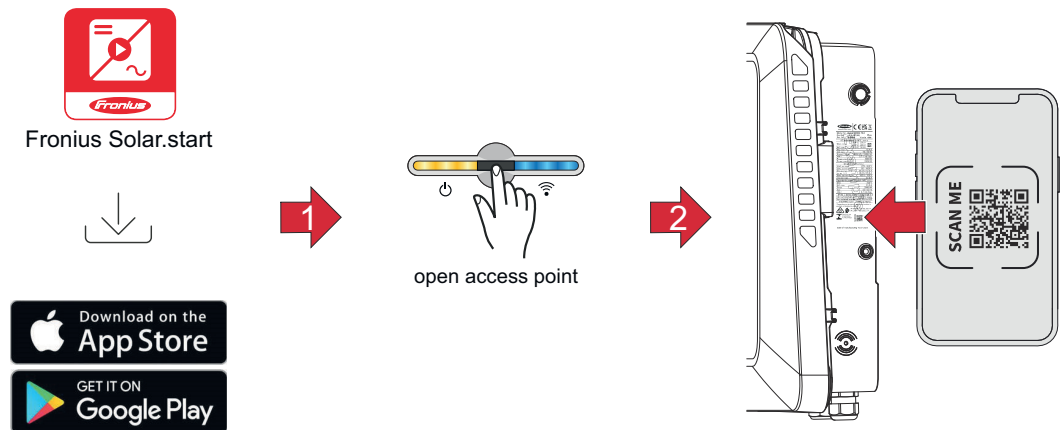

- 1 Download and install the Fronius Solar.start app.
- 2 Open the access point by touching the sensor
  - ✓ *Communications LED flashes blue.*
- 3 Scan the QR code on the rating plate using a smartphone or tablet.
- 4 Follow the installation wizard and complete the installation in the individual areas.
- 5 Add system components in Solar.web and commission the PV system.

The network wizard and product setup can be performed independently. A network connection is required for the Solar.web installation wizard.

## Installation with the browser

### WLAN:

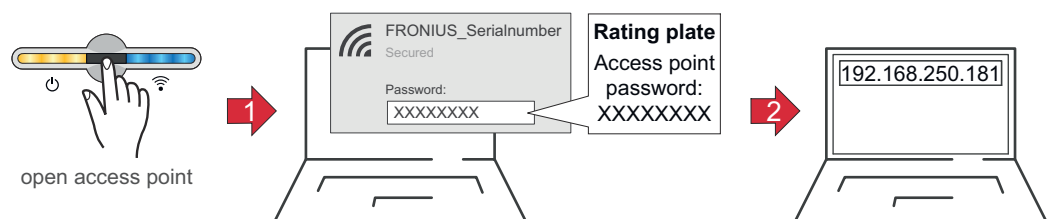

- 1 Open the access point by touching the sensor
  - ✓ *Communications LED flashes blue.*
- 2 Establish the connection to the inverter in the network settings (the inverter is displayed with the name "FRONIUS\_" and the serial number of the device).
- 3 Enter the password from the rating plate and confirm.
 

**IMPORTANT!**

To enter the password in Windows 10, first select the "Connect using a security key instead" link to be able to establish the connection with the password.
- 4 Enter the IP address 192.168.250.181 in the address bar of the browser and confirm. The installation wizard opens.
- 5 Follow the installation wizard and complete the installation in the individual areas.
- 6 Add the system components in Solar.web and commission the PV system.



The network wizard and product setup can be performed independently. A network connection is required for the Solar.web installation wizard.

### Ethernet:

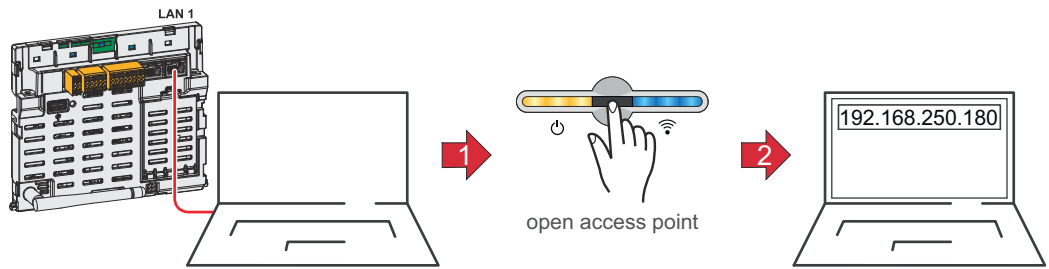

- 1** Establish a connection to the inverter (LAN1) using a network cable (min. CAT5 STP).
- 2** Open the access point by touching the sensor once   
✓ *Communications LED flashes blue.*
- 3** Enter the IP address 169.254.0.180 in the address bar of the browser and confirm. The installation wizard opens.
- 4** Follow the installation wizard and complete the installation in the individual areas.
- 5** Add the system components in Solar.web and commission the PV system.

The network wizard and product setup can be performed independently. A network connection is required for the Solar.web installation wizard.

# De-energizing the inverter and switching it back on

**De-energizing the inverter and switching it back on**

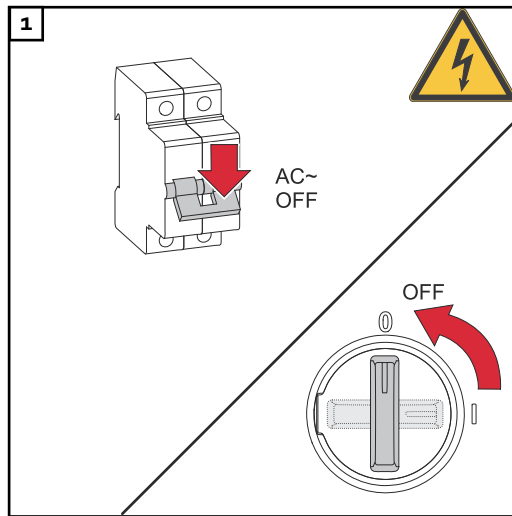

1. Turn off the automatic circuit breaker.
2. Turn the DC disconnect to the "Off" switch setting.

To start up the inverter again, follow the steps listed above in reverse order.

# **Settings – User interface of the in- verter**



# User settings

---

## User login

- 1 Open the user interface of the inverter in the browser.
- 2 In the menu field "**Log In**", log in with username and password, or, in the menu field "**User**", click on the "**User login**" button and log in with username and password.

### **IMPORTANT!**

Depending on the authorization of the user, settings can be made in the individual menu fields.

---

## Selecting languages

- 1 In the menu field "**User**", click the "**Language**" button and select the desired language.

# Device configuration

---

## Components

All available components of the system can be added via **"Add component+"**.

---

### **PV generator**

Activate the MPP tracker and enter the connected PV output in the relevant field. In the case of combined solar module strings, "PV 1 + PV 2 connected in parallel" must be activated.

---

### **Primary meter**

For problem-free operation with further energy generators and in Full Backup power operation, it is important to install the Fronius Smart Meter at the feed-in-point. The inverter and further producers must be connected to the public grid via the Fronius Smart Meter.

This setting also has an effect on the behavior of the inverter during the night. If the function is deactivated, the inverter switches into standby mode as soon as there is no more PV power available. The message "Power low" is displayed. The inverter starts again as soon as sufficient PV power is available.

If the function is activated, the inverter remains permanently connected to the grid in order to draw energy from other producers at any time.

After connecting the meter, the position must be configured. An individual Modbus address must be set for each Smart Meter.

The Watt value at the generator meter is the sum of all the generator meters.

The Watt value at the load meter is the sum of all the load meters.

---

## Functions and I/Os

### **Backup power**

In backup power mode, it is possible to select between "Off" and "PV Point".

### **IMPORTANT!**

The notes in the chapter headed [Safety](#) on page [59](#) must be observed when configuring the "PV Point" backup power mode.

### **Backup power nominal voltage**

When backup power mode is activated, the nominal voltage of the public grid must be selected.

---

### **Load management**

Up to four pins for the load management can be selected here. Further settings for the load management are available in the **"Load management"** menu item.

Default: Pin 1

---

## Inverter

### **"Force standby"**

When this function is activated, the supply of energy from the inverter into the grid is interrupted. This makes it possible to shut down the inverter without power and protect its components. The standby function is automatically deactivated when the inverter is restarted.

---

## "PV 1" and "PV 2"

| Parameter              | Value range | Description   |
|------------------------|-------------|---|
| "Mode"                 | Off         | The MPP tracker is deactivated.   |
|                        | Auto        | The inverter uses the voltage at which the max. possible output of the MPP tracker is possible.   |
|                        | Fixed       | The MPP tracker uses the voltage defined in "UDC fixed".  |
| "UDC fixed"            | 80 - 530 V  | The inverter uses the fixed voltage that is used on the MPP tracker.  |
| "Dynamic Peak Manager" | Off         | Function is deactivated.  |
|                        | On          | The entire solar module string is checked for optimization potential and determines the best possible voltage for the supply of energy from the inverter into the grid. |
|                        | On (MLSD)   | The entire solar module string is checked for optimization. The inverter can communicate with module level shutdown devices (MLSD).                                     |

### "Ripple control signal"

Ripple control signals are signals that are sent by the energy company in order to switch controllable loads on and off. Depending on the installation situation, ripple control signals can be dampened or amplified by the inverter. This can be counteracted if necessary by applying the following settings.

| Parameter                                | Value range       | Description   |
|--|-------------------|---|
| "Reduction of influence"                 | Off               | Function is deactivated.  |
|  | On                | Function is activated.  |
| "Frequency of the ripple control signal" | 100 - 3000 Hz     | The frequency specified by the energy company must be entered here. |
| "Grid inductance"                        | 0.00001 - 0.005 H | The value measured at the infeed point must be entered here.        |

### "Measures to prevent FI/RCMU false alarms"

(when using a 30 mA residual current circuit breaker)

#### **NOTE!**

**A residual current circuit breaker for the AC connecting cable may be required depending on national regulations, the grid operator, and other conditions.**

A type A residual current circuit breaker is generally sufficient in this case. Nevertheless, false alarms can be triggered for the type A residual current circuit breaker in individual cases and depending on local conditions. For this reason, Fronius recommends using a residual current circuit breaker suitable for frequency inverters with a release current of least 100 mA, taking into account national provisions.

| Parameter  | Value range                 | Description  |
|--|-----------------------------|--|
| "Inverter shut-down before 30 mA FI triggers"              | 0                           | No measures to prevent false alarms.   |
|  | 1                           | The inverter shuts down at 15 mA, before the residual current circuit breaker is triggered.  |
| "Leakage current factor for reducing RCMU/FI false alarms" | 0 - 0.25<br>(default: 0.16) | By reducing the set value, the leakage current is reduced and the intermediate circuit voltage is increased, which slightly lowers the efficiency. A set value of 0.16 ensures optimum efficiency. |

#### "Insulation warning"

| Parameter                              | Value range                | Description   |
|--|----------------------------|---|
| "Insulation warning"                   | Off                        | The insulation warning is deactivated.  |
|  | On                         | The insulation warning is activated. A warning is output in the event of an insulation fault.   |
| "Insulation measurement mode"          | Exact                      | Insulation monitoring takes place with the highest degree of accuracy and the measured insulation resistance is displayed on the user interface of the inverter.  |
|  | Fast                       | Insulation monitoring takes place with a lesser degree of accuracy, whereby the time to take the insulation measurement is shortened and the insulation value is not displayed on the user interface of the inverter. |
| "Threshold for the insulation warning" | 100000 - 10000000 $\Omega$ | If the value drops below the threshold, status code 1083 is displayed on the user interface of the inverter.  |

#### "Backup power"

| Parameter   | Value range | Description   |
|---|-------------|---|
| "Backup power nominal voltage"                                  | 220 - 240 V | The nominal phase voltage that is output in backup power mode.  |
| "Backup power undervoltage protection limit value $U_{<}$ [pu]" | 0 - 2 % V   | This set value represents the limit value for shutting down backup power mode. e. g., set value 0.9 = 90 % of the nominal voltage.  |
| "Backup power undervoltage protection time $U_{<}$ "            | 0.04 - 20 s | Trip time for falling below the backup power undervoltage protection limit value.   |
| "Backup power surge protection limit value $U_{>}$ [pu]"        | 0 - 2 % V   | This set value represents the limit value for shutting down backup power mode. e. g., set value 1.1 = 110 % of the nominal voltage. |
| "Backup power surge protection time $U_{>}$ "                   | 0.04 - 20 s | Trip time for exceeding the backup power surge protection limit value.  |



| <b>Parameter</b>   | <b>Value range</b> | <b>Description</b>   |
|--|--------------------|--|
| "Backup power restart delay"   | 0 - 600 s          | Waiting time for restarting backup power mode following a shutdown.  |
| "Backup power restart attempts"  | 1 - 10             | The max. number of automated restart attempts. Once the max. number of automated restart attempts has been reached, service message 1177 must be manually acknowledged.  |
| "External frequency monitoring in backup power mode"<br>(only for Italy) | Off                | Function is deactivated  |
|  | On                 | For Full Backup power mode in Italy, external frequency monitoring must be activated. The mains frequency is checked before ending backup power mode. If the mains frequency is within the permitted limits, the loads in the public grid are connected. |
| "Backup power short circuit switch-off time"                             | 0.001 - 60 s       | If a short circuit occurs during backup power mode, backup power mode is interrupted within the set time.  |

# Load management

---

## Load management

### "Rules"

It is possible for up to four different load management rules to be defined. At the same threshold values, the rules are activated in succession. For deactivation, this is done in reverse; the I/O last switched on is the first to be switched off. In the case of different thresholds, the I/O with the lowest threshold is switched on first, followed by the second lowest, and so on.

### **IMPORTANT!**

An I/O is activated/deactivated after 60 seconds.

### "Load"

- Control is **"Off"** (deactivated).
- Control is effected by the **"Power generated"**.
- Control is effected by **"Excess power"** (with feed-in limits). This option can only be selected if a meter has been connected. Control is effected using the actual power of feeding in with respect to the grid.

### "Thresholds"

- **"On"**: For entering an effective power limit, at which the output is activated.
- **"Off"**: For entering an effective power limit, at which the output is deactivated.

### "Runtimes"

- Field for activating the **"Minimum runtime per switch-on process"** for which the output is to be activated for each switch-on process.
- Field for activating the **"Maximum runtime per day"**.
- Field for activating the **"Target runtime"** for which the output is to be activated in total per day (several switch-on processes are allowed for).

# System

---

## General

### General settings

- 1 Enter the name of the system in the input field "**System name**" (max. 30 characters).
  - 2 Activate "**Synchronize time automatically**" → select "Timezone Region" and "Timezone Location". The date and time are taken over from the time zone entered.
  - 2 Deactivate "**Synchronize time automatically**" → enter or select "Date", "Time", "Timezone Region", and "Timezone Location".
  - 3 Click "**Save**".
- 

## Update

All available updates are provided on the product page and in the "Download Search" area at [www.fronius.com](http://www.fronius.com) .

### Updating the firmware

- 1 Drag the firmware file into the "drop file here" field, or select via "Select file".
- Update is started.
- 

## Setup wizard

The guided setup wizard can be accessed here.

---

## Restoring factory settings

### All settings

Resets all configuration data, apart from the country setup. Changes to the country setup may only be made by authorized personnel.

---

### All settings without network

Resets all configuration data, apart from the country setup and the network settings. Changes to the country setup may only be made by authorized personnel.

---

## Event log

**Current messages**All current events of the linked system components are displayed here.

### IMPORTANT!

Depending on the type of event, this must be confirmed via the "tick" button so that it can be further processed.

---

### History

All events of the linked system components that are no longer present are displayed here.

---

## Information

All information regarding the system and the current settings is displayed in this menu area.

---

### Saving as PDF

- 1 Click the "Save as PDF" button.
-

- 2 Select the information individually by ticking the check boxes beside the information or by ticking "Select all".
- 3 Enter the file name into the input field and click the "Save" button.

The PDF is created and shown.

---

## License manager

The power data and functional scope of the inverter are stored in the license file. If the inverter, power stage set or data communication area is replaced, the license file must also be replaced.

### Licensing - online (recommended):

This requires an Internet connection and a completed Solar.web configuration.

- 1 Finish all installation work (refer to the chapter headed [Closing the inverter's connection area/housing cover, and commissioning](#) on page 67).
- 2 Establish a connection to the user interface of the inverter.
- 3 Enter the serial number and verification code (VCode) of the defective and replacement device. The serial number and VCode can be found on the rating plate of the inverter (refer to the chapter headed [Warning notices on the device](#) on page 35).
- 4 Click the **"Start online licensing"** button.
- 5 Skip past the Terms and conditions of use and Network settings menu items by clicking **"Next"**.

License activation is started.

### Licensing - offline:

There must be no Internet connection in this case. If offline licensing is carried out while there is an active Internet connection, the license file is automatically loaded onto the inverter, resulting in the following error when the license file is uploaded: "The license has already been installed and the wizard can be closed".

- 1 Finish all installation work (refer to the chapter headed [Closing the inverter's connection area/housing cover, and commissioning](#) on page 67).
- 2 Establish a connection to the user interface of the inverter.
- 3 Enter the serial number and verification code (VCode) of the defective and replacement device. The serial number and VCode can be found on the rating plate of the inverter (refer to the chapter headed [Warning notices on the device](#) on page 35).
- 4 Click the **"Start offline licensing"** button.
- 5 Download the service file onto the mobile device by clicking the **"Download service file"** button.
- 6 Open [licensemanager.solarweb.com](http://licensemanager.solarweb.com) and log in with username and password.
- 7 Drag the service file into the **"Drag service file here or click to upload"** field or click to upload it.
- 8 Download the newly generated license file onto the mobile device by clicking the **"Download license file"** button.
- 9 Switch to the user interface of the inverter and drag the license file into the "Drop license file here" field or select via "Select license file".

License activation is started.

---

## Support

### Activating the support user

- 1 Click the **"Activate support user"** button.

The support user is activated.

**IMPORTANT!**

The support user exclusively enables Fronius Technical Support to configure settings on the inverter via a secure connection. Access is deactivated by clicking the **"End support user access"** button.

---

**Creating support info** (for Fronius Support team)

- 1** Click the **"Create support info"** button.
- 2** The sdp.cry file is downloaded automatically. For manual download, click the **"Download support info"** button.

The sdp.cry file is saved in the downloads.

---

**Activating remote maintenance**

- 1** Click the **"Activate remote maintenance"** button.

Remote maintenance access for the Fronius Support team is activated.

**IMPORTANT!**

The remote maintenance access exclusively enables Fronius Technical Support to access the inverter via a secure connection. In this case, diagnostics data is transmitted which is used for troubleshooting. The remote maintenance access can be activated only upon request by the Fronius Support team.

# Communication

---

## Network

### Server addresses for data transfer

If a firewall is used for outgoing connections, the following protocols, server addresses and ports must be allowed for successful data transfer:

- Tcp fronius-se-iot.azure-devices.net:8883
- Tcp fronius-se-iot-telemetry.azure-devices.net:8883
- Tcp fronius-se-iot-telemetry.azure-devices.net:443
- Udp sera-gen24.fronius.com:1194 (213.33.117.120:1194)
- Tcp cure-se.fronius.com:443
- Tcp firmware-download.fronius.com:443
- Tcp froniusseiot.blob.core.windows.net:443
- Tcp provisioning.solarweb.com:443
- Upd/Tcp O.time.fronius.com:123

When using FRITZ!Box products, the Internet access must be configured to be unlimited and unrestricted. The DHCP Lease Time (validity) must not be set to 0 (=infinite).

---

### LAN:



#### Establishing a connection:

- 1 Enter host name.
- 2 Select connection type "**automatic**" or "**static**".
- 3 For connection type "**static**" - enter IP address, subnet mask, DNS and gateway.
- 4 Click on the "**Connect**" button.

The connection is established. After connecting, the status of the connection should be checked (see chapter "[Internet services](#)" on page [85](#)).

---

### WLAN:



#### Establishing a connection via WPS:

- 1 Click the "**Enable**" button.
- 2 Activate WPS on the WLAN router (see documentation provided with the WLAN router).

The connection is established automatically. After connecting, the status of the connection should be checked (see chapter "[Internet services](#)" on page [85](#)).

#### Selecting and connecting to a WLAN network:

The networks found are shown in the list. Clicking on the refresh button  will carry out a second search of the available WLAN networks. The "**Find network**" input field can be used to further restrict the selection list.

- 1 Select network from the list.
- 2 Select connection type "**automatic**" or "**static**".

- 3 For connection type **"automatic"** - enter WLAN password and host name.
- 4 For connection type **"static"** - enter IP address, subnet mask, DNS and gateway.
- 5 Click on the **"Connect"** button.

The connection is established. After connecting, the status of the connection should be checked (see chapter **"Internet services"** on page 85).

---

#### Access point:



The inverter serves as an access point. A PC or smart device connects directly to the inverter. It is not possible to connect to the internet. The **"Network name (SSID)"** and **"Network key (PSK)"** can be assigned in this menu. It is possible to operate a connection via WLAN and via access point simultaneously.

---

## Modbus

### Modbus RTU interface 0 / 1

If one of the two Modbus RTU interfaces is set to Slave, the following input fields are available:

---

#### "Baud rate"

The baud rate influences the transmission speed between the individual components connected in the system. When selecting the baud rate, ensure that it is the same at both the sending and receiving end.

---

#### "Parity"

The parity bit can be used to check the parity. It detects transmission errors. A parity bit can safeguard a specific number of bits. The value (0 or 1) of the parity bit must be calculated by the sender and is checked by the recipient using the same calculation. The parity bit can be calculated for even and odd parity.

---

#### "SunSpec Model Type"

Depending on the SunSpec model, there are two different settings.

**float:** SunSpec Inverter Model 111, 112, 113 or 211, 212, 213 or 701, 702, 703, 704, 705, 706, 707, 708, 709, 710, 711, 712, 713

**int + SF:** SunSpec Inverter Model 101, 102, 103 or 201, 202, 203 or 701, 702, 703, 704, 705, 706, 707, 708, 709, 710, 711, 712, 713

---

#### "Meter address"

The value entered is the identification number (Unit ID) assigned to the meter. Can be found on the user interface of the inverter in the **"Communication"** → **"Modbus"** menu.

Factory setting: 200

---

#### "Meter address"

The value entered is the identification number (Unit ID) assigned to the meter. Can be found on the user interface of the inverter in the **"Communication"** → **"Modbus"** menu.

Factory setting: 1

---

### Slave as Modbus TCP

If the function **"Slave as Modbus TCP"** is activated, the following input fields are available:

**"Modbus port"**

Number of the TCP port that is to be used for Modbus communication.

**"SunSpec Model Type"**

Depending on the SunSpec model, there are two different settings.

**float:** SunSpec Inverter Model 111, 112, 113 or 211, 212, 213 or 701, 702, 703, 704, 705, 706, 707, 708, 709, 710, 711, 712, 713

**int + SF:** SunSpec Inverter Model 101, 102, 103 or 201, 202, 203 or 701, 702, 703, 704, 705, 706, 707, 708, 709, 710, 711, 712, 713

**"Meter address"**

The value entered is the identification number (Unit ID) assigned to the meter. Can be found on the user interface of the inverter in the **"Communication"** → **"Modbus"** menu.

Factory setting: 200

**"Meter address"**

The value entered is the identification number (Unit ID) assigned to the meter. Can be found on the user interface of the inverter in the **"Communication"** → **"Modbus"** menu.

Factory setting: This value is invariably defined as 1.

**Inverter control via Modbus**

If this option is activated, the inverter is controlled via Modbus.

Inverter control includes the following functions:

- on/off
- Power reduction
- Specification of a constant power factor (cos phi)
- Specification of a constant reactive power value

**Remote control****Remote control and Profiles**

The grid operator/energy supplier can influence the output power of the inverter via remote control. This requires the inverter to have an active Internet connection.

| Parameter  | Value range               | Description   |
|--|---------------------------|---|
| <b>Remote control</b>  | Off                       | The remote control of the inverter is deactivated.  |
|  | On                        | The remote control of the inverter is activated.  |
| <b>Allow remote control for regulation purposes (technician)</b> | Deactivated/<br>Activated | The <b>Allow remote control for regulation purposes</b> function may be mandatory for proper operation of the system. *)  |
| <b>Allow remote control for virtual power plants (customer)</b>  | Deactivated/<br>Activated | If the <b>Allow remote control for regulation purposes</b> function is activated (technician access required), the <b>Allow remote control for virtual power plants</b> function is automatically activated and cannot be deactivated. *) |

**\*) Cloud control**

A virtual power plant is an interconnection of multiple generators to form a group. This group can be controlled by means of the cloud control via the Inter-



net. An active inverter Internet connection is a prerequisite for this. System data is transferred.

---

### **Fronius Solar API**

The Fronius Solar API is an IP-based, open JSON interface. If it is activated, IOT devices in the local network can access inverter information without authentication. For security reasons, the interface is deactivated ex works and must be activated if it is required for a third-party application (e.g., EV charger, Smart Home solutions, etc.).

For monitoring, Fronius recommends using Fronius Solar.web, which offers secure access to the inverter status and production information.

In the event of a firmware update to version 1.14.x, the setting is taken from the Fronius Solar API. In systems with a version below 1.14.x, the Solar API is activated; with higher versions, it is deactivated but can be switched on and off via the menu

#### **Activating the Fronius Solar API**

Activate the **“Activate communication via Solar API”** function in the menu area **“Communication”** → **“Solar API”** on the user interface of the inverter.

---

### **Internet services**

Information regarding connections and the current connection status is displayed in this menu. If there are problems with the connection, a short description of the error is displayed.

# Safety and grid requirements

---

## Country setup

### **WARNING!**

#### **Danger due to unauthorised error analyses and repair work.**

This can result in serious injury and damage to property.

- ▶ Fault analyses and repair work on the photovoltaic system may only be carried out by installers/service technicians from authorised specialist companies in accordance with national standards and guidelines.
- 

### **NOTE!**

#### **Risk due to unauthorised access.**

Incorrectly set parameters can negatively influence the public grid and/or the inverter feeding energy into the grid, and lead to a loss of conformity with the standard.

- ▶ The parameters may only be adjusted by installers/service technicians from authorised specialist companies.
  - ▶ Do not give the access code to third parties and/or unauthorised persons.
- 

### **NOTE!**

#### **Risk due to incorrectly set parameters.**

Incorrectly set parameters can negatively influence the public grid and/or cause faults and failures on the inverter, and lead to the loss of conformity with the standard.

- ▶ The parameters may only be adjusted by installers/service technicians from authorised specialist companies.
  - ▶ The parameters may only be adjusted if the energy provider permits or requires this.
  - ▶ Only adjust the parameters taking into account the nationally applicable standards and/or directives and the specifications of the energy provider.
- 

The "Country Setup" menu area is intended exclusively for installers/service technicians from authorised specialist companies. To request the access code required for this menu area, see chapter [Requesting inverter codes in Solar.SOS](#).

The selected country setup for the respective country contains preset parameters according to the nationally applicable standards and requirements. Depending on local grid conditions and the specifications of the energy provider, adjustments to the selected country setup may be necessary.

---

## **Requesting inverter codes in Solar.SOS**

The "Country Setup" menu area is intended exclusively for installers/service technicians from authorised specialist companies. The inverter access code required for this menu area can be requested in the Fronius Solar.SOS portal.

Requesting inverter codes in Solar.SOS:

- 1** Go to [solar-sos.fronius.com](https://solar-sos.fronius.com) in a browser
- 2** Log in with your Fronius account
- 3** On the top right, click on the drop-down menu 
- 4** Select the menu item **Show inverter codes**

- 5 A contract page appears on which the request for the access code to change the grid parameters for Fronius inverters is located
- 6 Accept the Terms of use by checking **Yes, I have read and agree to the terms of use** and click **Confirm & Save**
- 7 After that, the codes can be retrieved in the drop-down menu at the top right under **Show inverter codes**

 **CAUTION!**

**Risk due to unauthorised access.**

Incorrectly set parameters can negatively influence the public grid and/or the inverter feeding energy into the grid, and lead to a loss of conformity with the standard.

- ▶ The parameters may only be adjusted by installers/service technicians from authorised specialist companies.
- ▶ Do not give the access code to third parties and/or unauthorised persons.

---

## Feed-in limit

Energy companies or grid operators can prescribe feed-in limits for an inverter (e.g., max. 70% of the kWp or max. 5 kW).

The feed-in limit takes account of self-consumption in the household before the power of an inverter is reduced:

- An individual limit can be set.
- A Fronius Smart Meter can be connected to the Modbus push-in terminal of the data communication area, at the terminals MO/M1- / MO/M1+ for Modbus data.

The feed-in limit only becomes active if the power of feeding in is higher than the set power reduction.

### "Off"

The inverter converts all available PV energy and feeds it into the public grid.

### "Limit for the entire system"

The entire PV system is limited to a fixed power limit. A value must be set for the permissible total power of feeding in.

### "Total DC power of the system"

Input field for the total DC power of the system in Wp.

This value is used if the "**Maximum permitted power of feeding in of the entire system**" is specified in %.

### "Hard limit"

If this value is exceeded, the inverter switches off within max. 5 seconds. This value must be higher than the value set for "**Soft limit**".

### "Soft limit"

If this value is exceeded, the inverter readjusts down to the set value within the time required by the national standards and regulations.

### "Maximum permitted power of feeding in of the entire system"

Input field for the "Maximum permitted power of feeding in of the entire system" in W or % (setting range: -10 to 100%).

If there is no meter in the system or if a meter has failed, the inverter limits the power of feeding in to the set value.

| <b>Example: Feed-in limit<br/>(not taking into account the efficiency)</b>  |              |
|---|--------------|
| PV system to Fronius inverter:  | 5000 W       |
| Consumption in home:  | 1000 W       |
| Maximum permitted power of feeding in of the entire system:   | 60% = 3000 W |
| In this example, only 3000 W may be fed into the grid at the grid feed-in point. However, loads that are located between the inverter and grid feed-in point can be supplied by means of additional feed-in of the inverter and are adjusted. |              |

## I/O power management

### General

In this menu item, settings relevant for a distribution network operator (DNO) are made. An effective power limitation in % and/or a power factor limitation can be set.

### IMPORTANT!

Select the **"Technician"** user for settings in this menu item, enter and the password for the **"Technician"** user and confirm. Settings in this menu area must only be made by trained and qualified personnel.

**"Input pattern"** (assignment of individual I/Os)

- 1 click = white (contact open)
- 2 clicks = blue (contact closed)
- 3 clicks = grey (not used)

**"Power factor (cos φ)"**

- "ind"** = inductive
- "cap"** = capacitive

**"DNO feedback"**

When the rule is enabled, output **"DNO feedback"** (pin 1 recommended) must be configured (e.g. for operating a signalling device).

For **"Import"** or **"Export"**, the data format \*.fpc is supported.

### Control priorities

For setting the control priorities for the ripple control signal receiver, the export limitation and control via Modbus.

1 = highest priority, 3 = lowest priority

## Connection diagram - 4 relays

The ripple control signal receiver and the I/O terminal of the inverter can be connected to one another as shown in the connection diagram.

For distances of over 11 yd between the inverter and the ripple control signal receiver, a CAT 5 cable is recommended as a minimum and the shielding must be connected on one side at the push-in terminal of the data communication area (SHIELD).

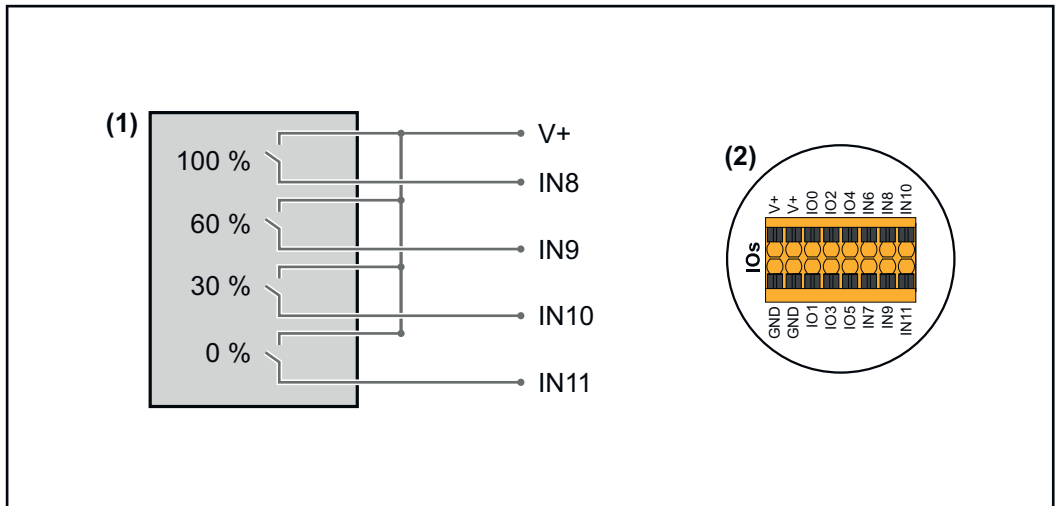

- (1) Ripple control signal receiver with 4 relays for effective power limitation.
- (2) I/Os of the data communication area.

**Use pre-configured file for 4-relay operation:**

- 1** Download the file (.fpc) under **4-relay operation** to the mobile device.
- 2** Upload the file (.fpc) in the "**I/O power management**" menu field by clicking the "**Import**" button.
- 3** Click "**Save**".

The settings for 4-relay operation are saved.

# I/O power management settings - 4 relays

## I/O Power Management

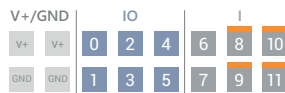

DNO Feedback  
not used

### DNO Rules

**Rule 1**

IO selection: 0, 2, 4, 6, 8, 10, 1, 3, 5, 7, 9, 11

Active Power: 100

Power Factor (cos φ): 1, cap

DNO Feedback:

**Rule 2**

IO selection: 0, 2, 4, 6, 8, 10, 1, 3, 5, 7, 9, 11

Active Power: 60

Power Factor (cos φ): 1, cap

DNO Feedback:

**Rule 3**

IO selection: 0, 2, 4, 6, 8, 10, 1, 3, 5, 7, 9, 11

Active Power: 30

Power Factor (cos φ): 1, cap

DNO Feedback:

**Rule 4**

IO selection: 0, 2, 4, 6, 8, 10, 1, 3, 5, 7, 9, 11

Active Power: 0

Power Factor (cos φ): 1, cap

DNO Feedback:

- 0 None
- 1 None
- 2 None
- 3 None
- 4 None
- 5 None
- 6 None
- 7 None
- 8 IO control
- 9 IO control
- 10 IO control
- 11 IO control

IMPORT EXPORT

### Connection diagram - 3 relays

The ripple control signal receiver and the I/O terminal of the inverter can be connected to one another as shown in the connection diagram.

For distances of over 11 yd between the inverter and the ripple control signal receiver, a CAT 5 cable is recommended as a minimum and the shielding must be connected on one side at the push-in terminal of the data communication area (SHIELD).

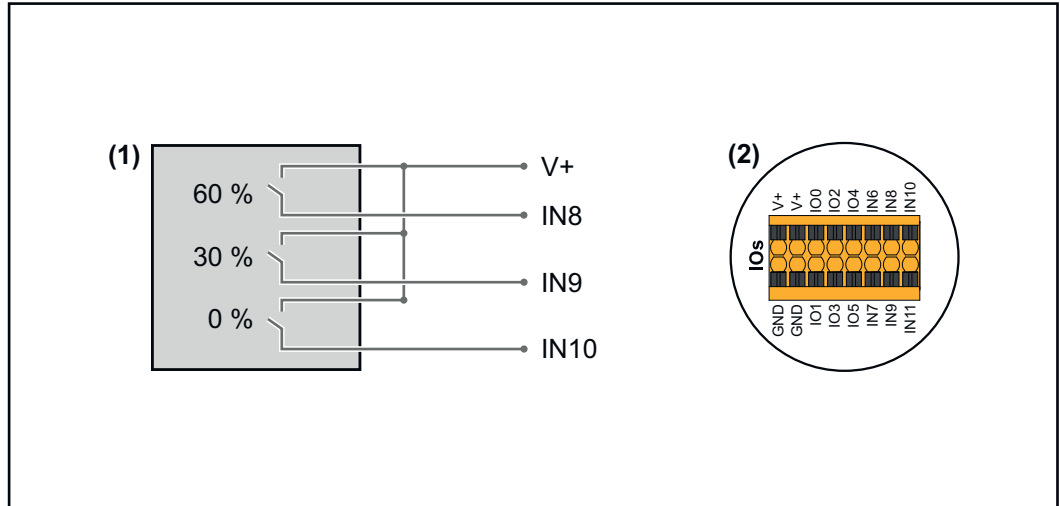

- (1) Ripple control signal receiver with 3 relays for effective power limitation.
- (2) I/Os of the data communication area.

#### Use pre-configured file for 3-relay operation:

- 1 Download the file (.fpc) under **3-relay operation** to the mobile device.
- 2 Upload the file (.fpc) in the "**I/O power management**" menu field by clicking the "**Import**" button.
- 3 Click "**Save**".

The settings for 3-relay operation are saved.

## I/O power management settings - 3 relays

## I/O Power Management

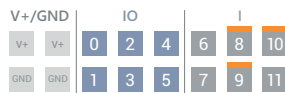

DNO Feedback  
not used

### DNO Rules

**Rule 1**

0 2 4 6 8 10  
1 3 5 7 9 11

Active Power: 100

Power Factor (cos φ): 1 cap

DNO Feedback:

**Rule 2**

0 2 4 6 8 10  
1 3 5 7 9 11

Active Power: 60

Power Factor (cos φ): 1 cap

DNO Feedback:

**Rule 3**

0 2 4 6 8 10  
1 3 5 7 9 11

Active Power: 30

Power Factor (cos φ): 1 cap

DNO Feedback:

**Rule 4**

0 2 4 6 8 10  
1 3 5 7 9 11

Active Power: 0

Power Factor (cos φ): 1 cap

DNO Feedback:

- 0 None
- 1 None
- 2 None
- 3 None
- 4 None
- 5 None
- 6 None
- 7 None
- 8 **IO control**
- 9 **IO control**
- 10 **IO control**
- 11 None

↑ IMPORT

↓ EXPORT



**Connection diagram - 2 relays**

The ripple control signal receiver and the I/O terminal of the inverter can be connected to one another as shown in the connection diagram. For distances of over 11 yd between the inverter and the ripple control signal receiver, a CAT 5 cable is recommended as a minimum and the shielding must be connected on one side at the push-in terminal of the data communication area (SHIELD).

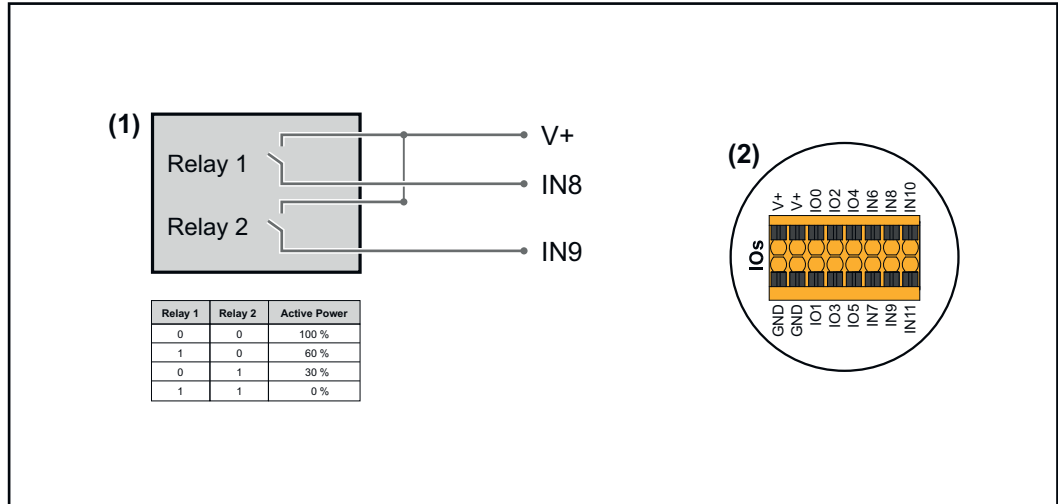

- (1) Ripple control signal receiver with 2 relays for effective power limitation.
- (2) I/Os of the data communication area.

**Use pre-configured file for 2-relay operation:**

- 1 Download the file (.fpc) under **2-relay operation** to the mobile device.
- 2 Upload the file (.fpc) in the **"I/O power management"** menu field by clicking the **"Import"** button.
- 3 Click **"Save"**.

The settings for 2-relay operation are saved.

## I/O power management settings - 2 relays

## I/O Power Management

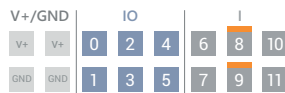

DNO Feedback  
not used

### DNO Rules

**Rule 1**

0 2 4 6 8 10  
1 3 5 7 9 11

Active Power: 100

Power Factor (cos φ): 1 cap

DNO Feedback:

**Rule 2**

0 2 4 6 8 10  
1 3 5 7 9 11

Active Power: 60

Power Factor (cos φ): 1 cap

DNO Feedback:

**Rule 3**

0 2 4 6 8 10  
1 3 5 7 9 11

Active Power: 30

Power Factor (cos φ): 1 cap

DNO Feedback:

**Rule 4**

0 2 4 6 8 10  
1 3 5 7 9 11

Active Power: 0

Power Factor (cos φ): 1 cap

DNO Feedback:

- 0 None
- 1 None
- 2 None
- 3 None
- 4 None
- 5 None
- 6 None
- 7 None
- 8 **IO control**
- 9 **IO control**
- 10 None
- 11 None

### Connection diagram - 1 relay

The ripple control signal receiver and the I/O terminal of the inverter can be connected to one another as shown in the connection diagram.

For distances of over 10 m between the inverter and the ripple control signal receiver, a CAT 5 cable is recommended as a minimum and the shielding must be connected on one side at the push-in terminal of the data communication area (SHIELD).

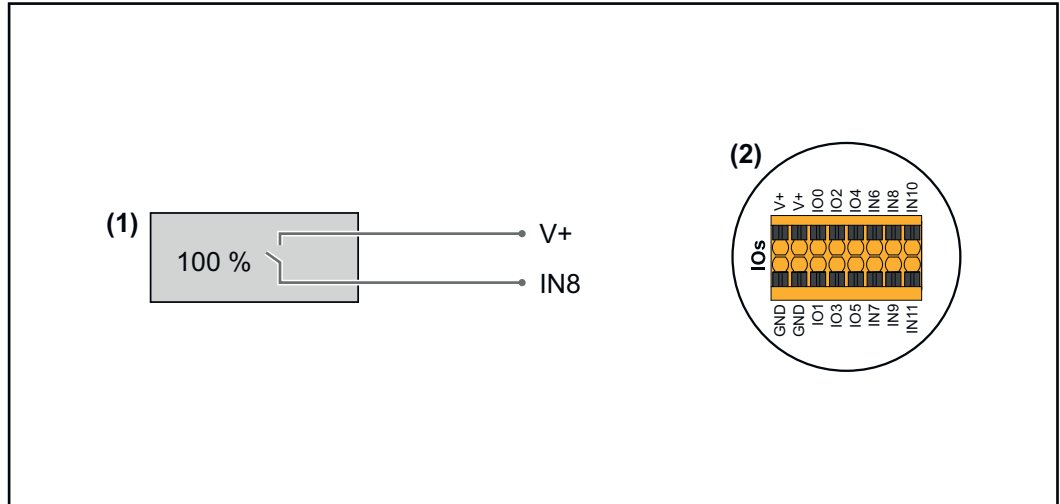

- (1) Ripple control signal receiver with 1 relay for effective power limitation.
- (2) I/Os of the data communication area.

#### Use pre-configured file for 1-relay operation:

- 1 Download the file (.fpc) under **1-relay operation** to the mobile device.
- 2 Upload the file (.fpc) in the "**I/O power management**" menu field by clicking the "**Import**" button.
- 3 Click "**Save**".

The settings for 1-relay operation are saved.

## I/O power management settings - 1 relay

## I/O Power Management

| V+/GND |     | IO |   |   |   |   |    |
|--------|-----|----|---|---|---|---|----|
| V+     | V+  | 0  | 2 | 4 | 6 | 8 | 10 |
| GND    | GND | 1  | 3 | 5 | 7 | 9 | 11 |

DNO Feedback  
not used

### DNO Rules

**Rule 1** ✕ ⏪ ⏩

|   |   |   |   |   |    |
|---|---|---|---|---|----|
| 0 | 2 | 4 | 6 | 8 | 10 |
| 1 | 3 | 5 | 7 | 9 | 11 |

Active Power  100

Power Factor (cos φ)  1 cap ▾

DNO Feedback

**Rule 2** ✕ ⏪ ⏩

|   |   |   |   |   |    |
|---|---|---|---|---|----|
| 0 | 2 | 4 | 6 | 8 | 10 |
| 1 | 3 | 5 | 7 | 9 | 11 |

Active Power  0

Power Factor (cos φ)  1 cap ▾

DNO Feedback

- 0 None
- 1 None
- 2 None
- 3 None
- 4 None
- 5 None
- 6 None
- 7 None
- 8 **IO control**
- 9 None
- 10 None
- 11 None

# Appendix



# Service, maintenance and disposal

---

**General** The inverter is designed so that it does not require additional maintenance work. Nevertheless, a few points must be considered during operation to ensure that the inverter works perfectly.

---

**Copyright** Copyright of these Operating Instructions remains with the manufacturer.

---

Text and illustrations were accurate at the time of printing. Fronius reserves the right to make changes. The contents of the Operating Instructions shall not provide the basis for any claims whatsoever on the part of the purchaser. If you have any suggestions for improvement, or can point out any mistakes that you have found in the Operating Instructions, we will be most grateful for your comments.

---

**Maintenance** Maintenance and service work may only be carried out by Fronius-trained service technicians.

---

**Cleaning** Wipe the inverter, if necessary, with a damp cloth. Do not use cleaning agents, scouring agents, solvents, or similar products to clean the inverter.

---

**Safety** The DC disconnect is used only to switch off power to the power stage set. When the DC disconnect is turned off, the connection area is still energized.

 **WARNING!**

**Danger from mains voltage and DC voltage from PV modules.**

This can result in severe personal injury and damage to property.

- ▶ The connection area must only be opened by an authorized electrician.
  - ▶ The separate power stage set area must only be opened by Fronius-trained service technicians.
  - ▶ Prior to any connection work, ensure that the inverter is de-energized on the AC side and the DC side.
- 

 **WARNING!**

**Danger of residual voltage from capacitors.**

This can result in severe personal injury and damage to property.

- ▶ Allow the capacitors of the inverter to discharge (2 minutes).
-

**Operation in dusty environments**

**NOTE!**

**If the inverter is operated in dusty environments, dirt may build up on the heat sink and fan.**

This may result in a loss of power due to insufficient cooling of the inverter.

- ▶ Make sure that the ambient air can always flow through the inverter's ventilation slots unimpeded.
- ▶ Remove any build-up of dirt on the heat sink and the fan.

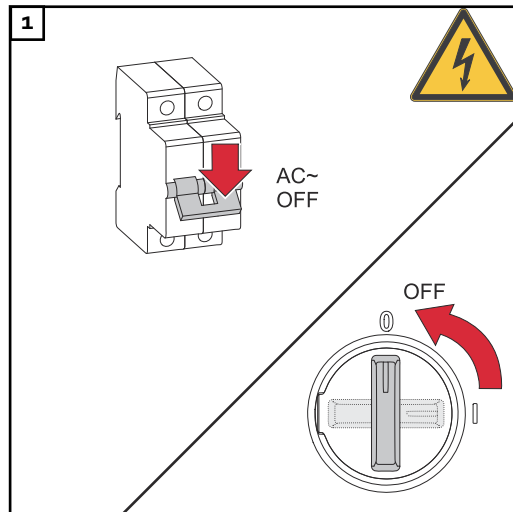

Switch off power to the inverter and wait for the specified time until the capacitors have discharged and the fan has shut down. Turn the DC disconnecter to the "Off" switch position.

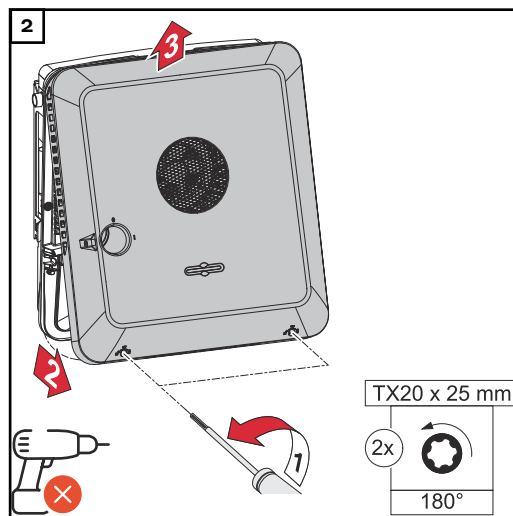

Loosen the screws on the underside of the housing cover by rotating them 180° to the left using a screwdriver (TX20). Then lift the housing cover away from the inverter at the bottom and detach from above.

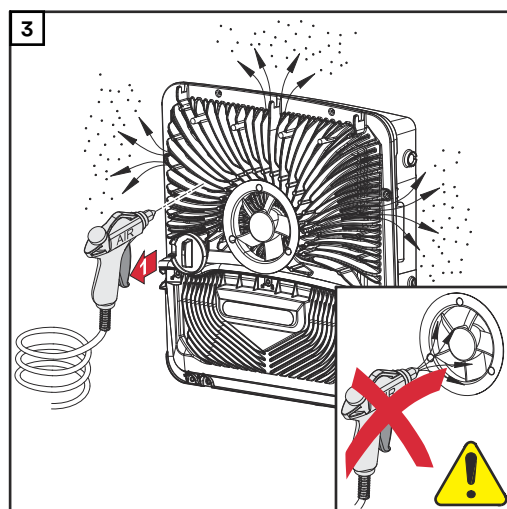

Remove any build-up of dirt on the heat sink and fan using compressed air, or a cloth or brush.

**NOTE!**

**Risk due to damage to the fan bearing from improper cleaning.**

Excessive speed and pressure on the fan bearing can cause damage.

- ▶ Block the fan and clean it with compressed air.
- ▶ When using a cloth or brush, clean the fan without applying pressure to the fan.



To start up the inverter again, follow the steps listed above in reverse order.

---

**Disposal**

Waste electrical and electronic equipment must be collected separately and recycled in an environmentally sound manner in accordance with the European Directive and national law. Used equipment must be returned to the distributor or through a local authorized collection and disposal system. Proper disposal of the used device promotes sustainable recycling of material resources. Failure to observe this may lead to potential health/environmental impacts.

**Packaging materials**

Separate collection. Check your municipality's regulations. Reduce the volume of the box.

# Warranty provisions

---

## **Fronius manufacturer's warranty**

Detailed warranty conditions specific to your country can be found online: <https://www.fronius.com/en/solar-energy/installers-partners/service-support/warranty-models>

To take advantage of the full warranty duration for your newly installed Fronius inverter or storage system, register your product at: [www.solarweb.com](http://www.solarweb.com)

# Status codes and remedy

---

## Display

Status codes are displayed on the user interface of the inverter in the **"System"** → **"Event Log"** menu or in the user menu under **"Notifications"** or in Fronius Solar.web\*.

\* with corresponding configuration, see chapter **Fronius Solar.web** on page **15**.

---

## Status codes

---

### 1030 – WSD Open (operating LED: flashes red)

**Cause:** A device that is connected in the WSD chain has interrupted the signal line (e.g., surge protection device) or the bypass installed ex works as standard has been removed and no trigger device has been installed.

**Remedy:** If the SPD surge protection device has tripped, the inverter must be repaired by an authorized specialist.

**OR:** Install the bypass installed ex works as standard or a trigger device.

**OR:** Turn the WSD (wired shutdown) switch to position 1 (WSD master).



#### **WARNING!**

#### **Danger from work that is not carried out properly.**

This can result in severe personal injury and damage to property.

- ▶ The installation and connection of an SPD surge protection device may only be carried out by Fronius-trained service personnel in accordance with the technical specifications.
  - ▶ Observe safety rules.
- 

---

### 1173 – ArcContinuousFault (operating LED: flashes red)

**Cause:** An electric arc has been identified on the PV system, and the maximum number of automatic connections within 24 hours has been reached.

**Remedy:** Keep the sensor pressed on the inverter for 3 seconds (max. 6 seconds).

**OR:** On the user interface of the inverter, in the menu field **"System"** → **"Event Log"**, confirm the status **"1173 – ArcContinuousFault"**.

**OR:** On the user interface of the inverter, in the user menu **"Messages"**, confirm the status **"1173 – ArcContinuousFault"**.



#### **CAUTION!**

#### **Danger from damaged components of the PV system**

This can result in severe personal injury/damage to property.

- ▶ Before the status **"1173 – ArcContinuousFault"** is confirmed, the entire PV system affected must be checked for any possible damage.
  - ▶ Damaged components must be repaired by qualified specialists.
- 

---

### 1191 – AfcIDataTransfer (operating LED: flashes yellow)

**Cause:** An electric arc has been identified on the PV system.

**Remedy:** No action required.

---

# Technical data

## Technical data for Fronius Primo GEN24 7.7 208 - 240

| DC input data   |                                  |                               |
|---|----------------------------------|-------------------------------|
| MPP voltage range   |                                  | 260 - 480 V                   |
| Max. input voltage<br>at 1000 W/m <sup>2</sup> /14 °F in an open circuit  |                                  | 600 V                         |
| Min. input voltage  |                                  | 65 V                          |
| Start-up input voltage  |                                  | 65 V                          |
| Nominal PV power  | at 208 V<br>at 220 V<br>at 240 V | 7920 W<br>7920 W<br>7920 W    |
| Nominal input voltage   | at 208 V<br>at 220 V<br>at 240 V | 365 V<br>365 V<br>385 V       |
| Max. PV array power   | at 208 V<br>at 220 V<br>at 240 V | 11520 W<br>11520 W<br>11520 W |
| Nominal input current   | at 208 V<br>at 220 V<br>at 240 V | 21.7 A<br>21.7 A<br>20.6 A    |
| Max. input current<br>PV 1<br>PV 2  |                                  | 22 A<br>22 A                  |
| Max. short circuit current for module array (I <sub>SC PV</sub> )<br>PV 1<br>PV 2                                       |                                  | 41.25 A<br>36 A               |
| Max. total short circuit current for module array<br>(I <sub>SC PV1</sub> + I <sub>SC PV2</sub> = I <sub>SC max</sub> ) |                                  | 77.25 A                       |
| Max. continuous utility backfeed current <sup>1)</sup>  |                                  | 0.0 A                         |

| AC output data   |                                  |                            |
|--|----------------------------------|----------------------------|
| Max. output power  | at 208 V<br>at 220 V<br>at 240 V | 7680 W<br>7680 W<br>7680 W |
| Max. output power at<br>+140 °F (60 °C) V min /<br>V max | at 208 V<br>at 220 V<br>at 240 V | 7680 W<br>7680 W<br>7680 W |
| Nominal AC voltage                                       |                                  | 208 V/220 V/240 V          |
| Voltage trip limit accuracy                              |                                  | 1% of nominal value        |
| Max. continuous out-<br>put current at V <sub>nom</sub>  | at 208 V<br>at 220 V<br>at 240 V | 36.9 A<br>34.9 A<br>32.0 A |
| Output overcurrent<br>protection                         | at 208 V<br>at 220 V<br>at 240 V | 50.0 A<br>45.0 A<br>40.0 A |
| Phases   |                                  | 1                          |

| <b>AC output data</b>   |                                  |  |
|---|----------------------------------|--|
| Max. output fault current per duration (peak / rms over duration)           | at 208 V<br>at 220 V<br>at 240 V | 682 A / 20.1 A over 396 ms<br>676 A / 35.4 A over 120 ms<br>698 A / 20.4 A over 339 ms |
| Nominal output frequency  |                                  | 60 Hz  |
| Setting range for mains frequency   |                                  | 45.0 - 66.0 Hz   |
| Frequency trip limit accuracy   |                                  | 0.01 Hz  |
| Total harmonic distortion   |                                  | < 3.0%   |
| Power factor (cos phi)  |                                  | 0.8 - 1 ind./cap. <sup>2)</sup>  |
| Max. permitted mains impedance Z <sub>max</sub> at PCC (mOhm) <sup>3)</sup> |                                  | None   |

| <b>General data</b>                   |                                  |   |
|---------------------------------------|----------------------------------|---|
| Maximum efficiency                    |                                  | 97.5 %  |
| CEC efficiency                        | at 208 V<br>at 220 V<br>at 240 V | 96.5 %<br>96.5 %<br>97.0 %                        |
| Night tare loss                       | at 208 V<br>at 220 V<br>at 240 V | 9.2 W<br>9.2 W<br>9.2 W                           |
| Cooling                               |                                  | Controlled forced-air ventilation                 |
| Protection class                      |                                  | Type 4X   |
| Dimensions H × W × D                  |                                  | 23.0 × 20.8 × 7.1 inches<br>(583 × 529 × 180 mm)  |
| Weight                                |                                  | 49.05 lbs. (22.25 kg)                             |
| Shipping dimensions H × W × D         |                                  | 25.8 × 23.5 × 10.4 inches<br>(654 × 598 × 263 mm) |
| Shipping weight                       |                                  | 57.10 lbs.(25.9 kg)                               |
| Inverter topology                     |                                  | non-isolated, no transformer                      |
| Permitted ambient temperature         |                                  | -40 °F - +140 °F<br><br>(-40 °C - +60 °C)         |
| Permissible humidity                  |                                  | 0 - 100%<br>(incl. condensation)                  |
| EMC emission class                    |                                  | B   |
| DC/AC overvoltage category            |                                  | 2/4   |
| Pollution degree                      |                                  | 2   |
| Safety class (according to IEC 62103) |                                  | 1   |

| <b>Protection devices</b> |                                     |
|---------------------------|-------------------------------------|
| DC isolation measurement  | Warning/shutdown at RISO < 500 kOhm |

| <b>Protection devices</b>            |   |
|--------------------------------------|---|
| DC overload performance              | Operating point shift, power limiter  |
| DC disconnect                        | Integrated  |
| DC reverse polarity protection       | Integrated  |
| Arc Fault Circuit Interrupter        | AFCI type 1 integrated, according to UL1699B:2021 and F-I-AFPE-1-4-1 according to IEC63027:2023 |
| Rapid shutdown                       | Integrated, in accordance with UL1741 and CSA C22.2 No.330-23                                   |
| RCMU                                 | Integrated  |
| Active anti-islanding method         | Integrated  |
| Behavior in the event of overheating | Power limiter, active cooling   |

| <b>Output data PV Point</b>    |   |          |        |          |        |          |        |
|--------------------------------|---|----------|--------|----------|--------|----------|--------|
| Nominal AC voltage PV Point    | 1~NPE 120 V / 220 V / 240 V   |          |        |          |        |          |        |
| Nominal output power PV Point  | <table border="0"> <tr> <td style="text-align: right;">at 120 V</td> <td>1560 W</td> </tr> <tr> <td style="text-align: right;">at 220 V</td> <td>2860 W</td> </tr> <tr> <td style="text-align: right;">at 240 V</td> <td>3120 W</td> </tr> </table> | at 120 V | 1560 W | at 220 V | 2860 W | at 240 V | 3120 W |
| at 120 V                       | 1560 W  |          |        |          |        |          |        |
| at 220 V                       | 2860 W  |          |        |          |        |          |        |
| at 240 V                       | 3120 W  |          |        |          |        |          |        |
| Max. continuous output current | <table border="0"> <tr> <td style="text-align: right;">at 120 V</td> <td>13.0 A</td> </tr> <tr> <td style="text-align: right;">at 220 V</td> <td>13.0 A</td> </tr> <tr> <td style="text-align: right;">at 240 V</td> <td>13.0 A</td> </tr> </table> | at 120 V | 13.0 A | at 220 V | 13.0 A | at 240 V | 13.0 A |
| at 120 V                       | 13.0 A  |          |        |          |        |          |        |
| at 220 V                       | 13.0 A  |          |        |          |        |          |        |
| at 240 V                       | 13.0 A  |          |        |          |        |          |        |
| Nominal output frequency       | 63 Hz   |          |        |          |        |          |        |
| Power factor                   | 0 - 1 ind. / cap. <sup>2)</sup>   |          |        |          |        |          |        |
| Switching time                 | <35 sec.  |          |        |          |        |          |        |

| <b>Data communication</b>  |   |
|--|---|
| WLAN SMA-RP connection<br>( <b>FCC ID:</b> QKWPILOT1 / <b>IC ID:</b> 12270-PILOT1 / <b>IFETEL:</b> RCPFRT20-1349) ( <b>FCC ID:</b> QKWPILOT2 / <b>IC ID:</b> 12270-PILOT2) | 802.11b/g/n (WPA, WPA2)   |
| Ethernet (LAN)   | RJ 45, 10/100 Mbit  |
| Wired shutdown (WSD)   | max. 28 devices/WSD chain<br><br>max. distance<br>master → slave = 109 yd / 100 m<br>slave → slave = 109 yd / 100 m |
| Modbus RTU SunSpec (2x)  | RS485 2-wire  |

| <b>Data communication</b>                        |   |
|--|---|
| Voltage level of digital inputs                  | low: min. 0 V - max. 1.8 V<br>high: min. 4.5 V - max. 28.8 V  |
| Input currents of digital inputs                 | depending on the input voltage;<br>input resistance = 70 kOhm |
| Total power for digital output (internal supply) | 6 W at 12 V (USB not connected)                               |
| Power per digital output (external supply)       | 1 A at >12.5 V - 24 V (max. 3 A in total)                     |

| <b>DC Input data battery<sup>4)</sup></b> |        |
|---|--------|
| Min. voltage                              | 150 V  |
| Max. voltage                              | 455 V  |
| Max. current                              | 22 A   |
| Max. output                               | 7680 W |
| DC Inputs                                 | 1      |

| <b>Output data Full Backup<sup>5)</sup></b> |          |                                   |
|---|----------|-----------------------------------|
| Nominal output power Full Backup            | at 120 V | 7680 W                            |
|   | at 220 V | 7680 W                            |
|   | at 240 V | 7680 W                            |
| Max. continuous output current              | at 120 V | 36.9 A                            |
|   | at 220 V | 34.9 A                            |
|   | at 240 V | 32.0 A                            |
| Nominal output frequency                    |          | 63 Hz                             |
| Power factor                                |          | 0.8 - 1 ind. / cap. <sup>2)</sup> |
| Switching time                              |          | <45 sec.                          |

**Technical data  
for Fronius  
Primo GEN24  
10.0 208 - 240**

| <b>DC input data</b>  |             |         |
|---|-------------|---------|
| MPP voltage range   | 260 - 480 V |         |
| Max. input voltage at 1000 W/m <sup>2</sup> /14 °F in an open circuit | 600 V       |         |
| Min. input voltage  | 65 V        |         |
| Start-up input voltage  | 65 V        |         |
| Nominal PV power  | at 208 V    | 9740 W  |
|   | at 220 V    | 10310 W |
|   | at 240 V    | 10310 W |
| Max. PV array power   | at 208 V    | 13500 W |
|   | at 220 V    | 13000 W |
|   | at 240 V    | 15000 W |

| DC input data  |                                  |                            |
|--|----------------------------------|----------------------------|
| Nominal input voltage  | at 208 V<br>at 220 V<br>at 240 V | 365 V<br>365 V<br>385 V    |
| Nominal input current  | at 208 V<br>at 220 V<br>at 240 V | 26.7 A<br>28.2 A<br>26.8 A |
| Max. input current<br>PV 1<br>PV 2   |                                  | 22 A<br>22 A               |
| Max. short circuit current for module array ( $I_{SC\ PV}$ )<br>PV 1<br>PV 2                       |                                  | 41.25 A<br>36 A            |
| Max. total short circuit current for module array<br>( $I_{SC\ PV1} + I_{SC\ PV2} = I_{SC\ max}$ ) |                                  | 77.25 A                    |
| Max. continuous utility backfeed current <sup>1)</sup>   |                                  | 0.0 A                      |

| AC output data   |                                  |  |
|--|----------------------------------|--|
| Max. output power  | at 208 V<br>at 220 V<br>at 240 V | 9450 W<br>10,000 W<br>10,000 W   |
| Max. output power at<br>+140 °F (60 °C) V min /<br>V max                       | at 208 V<br>at 220 V<br>at 240 V | 9450 W<br>10,000 W<br>10,000 W   |
| Nominal AC voltage   |                                  | 208 V/220 V/240 V  |
| Voltage trip limit accuracy  |                                  | 1% of nominal value  |
| Max. continuous output<br>current at $V_{nom}$                                 | at 208 V<br>at 220 V<br>at 240 V | 45.45 A<br>45.45 A<br>41.7 A   |
| Output overcurrent<br>protection   | at 208 V<br>at 220 V<br>at 240 V | 60 A<br>60 A<br>55 A   |
| Phases   |                                  | 1  |
| Max. output fault cur-<br>rent per duration<br>(peak / rms over dura-<br>tion) | at 208 V<br>at 220 V<br>at 240 V | 682 A/ 20.1 A over 396<br>ms<br>676 A/ 35.4 A over 120<br>ms<br>698 A/ 20.4 A over 339<br>ms |
| Nominal output frequency   |                                  | 60 Hz  |
| Setting range for mains frequency  |                                  | 45.0 - 66.0 Hz   |
| Frequency trip limit accuracy  |                                  | 0.05 Hz  |
| Total harmonic distortion  |                                  | < 3.0%   |
| Power factor (cos phi)   |                                  | 0.8 - 1 ind./cap. <sup>2)</sup>  |
| Max. permitted mains impedance $Z_{max}$ at PCC<br>(mOhm) <sup>3)</sup>        |                                  | None   |



| <b>General data</b>                   |                                  |   |
|---------------------------------------|----------------------------------|---|
| Maximum efficiency                    |                                  | 97.5%   |
| CEC efficiency                        | at 208 V<br>at 220 V<br>at 240 V | 96.5%<br>96.5%<br>97.0%                           |
| Night tare loss                       | at 208 V<br>at 220 V<br>at 240 V | 8.4 W<br>8.4 W<br>8.5 W                           |
| Cooling                               |                                  | Controlled forced-air ventilation                 |
| Protection class                      |                                  | Type 4X   |
| Dimensions H × W × D                  |                                  | 23.0 × 20.8 × 7.1 inches<br>(583 × 529 × 180 mm)  |
| Weight                                |                                  | 49.05 lbs. (22.25 kg)                             |
| Shipping dimensions W × H × D         |                                  | 25.8 × 23.5 × 10.4 inches<br>(654 × 598 × 264 mm) |
| Shipping weight                       |                                  | 57.10 lbs. (25.9 kg)                              |
| Inverter topology                     |                                  | non-isolated, no transformer                      |
| Permitted ambient temperature         |                                  | -40 °F - +140 °F (-40 °C<br>- +60 °C)             |
| Permissible humidity                  |                                  | 0 - 100%<br>(incl. condensation)                  |
| EMC emission class                    |                                  | B   |
| DC/AC overvoltage category            |                                  | 2/4   |
| Pollution degree                      |                                  | 2   |
| Safety class (according to IEC 62103) |                                  | 1   |

| <b>Protection devices</b>      |   |
|--------------------------------|---|
| DC isolation measurement       | Warning/shutdown at RISO < 500 kOhm   |
| DC overload performance        | Operating point shift, power limiter  |
| DC disconnect                  | Integrated  |
| DC reverse polarity protection | Integrated  |
| Arc Fault Circuit Interrupter  | AFCI type 1 integrated, according to UL1699B:2021 and F-I-AFPE-1-4-1 according to IEC63027:2023 |
| Rapid shutdown                 | Integrated, in accordance with UL1741 and CSA C22.2 No.330-23                                   |
| RCMU                           | Integrated  |
| Active anti-islanding method   | Integrated  |

| Protection devices                   |                               |
|--------------------------------------|-------------------------------|
| Behavior in the event of overheating | Power limiter, active cooling |

| Output data PV Point           |   |          |        |          |        |          |        |
|--------------------------------|---|----------|--------|----------|--------|----------|--------|
| Nominal AC voltage PV Point    | 1~NPE 120 V / 220 V / 240 V   |          |        |          |        |          |        |
| Nominal output power PV Point  | <table border="0"> <tr> <td style="padding-right: 20px;">at 120 V</td> <td>1560 W</td> </tr> <tr> <td>at 220 V</td> <td>2860 W</td> </tr> <tr> <td>at 240 V</td> <td>3120 W</td> </tr> </table> | at 120 V | 1560 W | at 220 V | 2860 W | at 240 V | 3120 W |
| at 120 V                       | 1560 W  |          |        |          |        |          |        |
| at 220 V                       | 2860 W  |          |        |          |        |          |        |
| at 240 V                       | 3120 W  |          |        |          |        |          |        |
| Max. continuous output current | <table border="0"> <tr> <td style="padding-right: 20px;">at 120 V</td> <td>13.0 A</td> </tr> <tr> <td>at 220 V</td> <td>13.0 A</td> </tr> <tr> <td>at 240 V</td> <td>13.0 A</td> </tr> </table> | at 120 V | 13.0 A | at 220 V | 13.0 A | at 240 V | 13.0 A |
| at 120 V                       | 13.0 A  |          |        |          |        |          |        |
| at 220 V                       | 13.0 A  |          |        |          |        |          |        |
| at 240 V                       | 13.0 A  |          |        |          |        |          |        |
| Nominal output frequency       | 63 Hz   |          |        |          |        |          |        |
| Power factor                   | 0 - 1 ind. / cap. <sup>2)</sup>   |          |        |          |        |          |        |
| Switching time                 | <35 sec.  |          |        |          |        |          |        |

| Data communication   |   |
|--|---|
| WLAN SMA-RP connection<br>( <b>FCC ID:</b> QKWPILOT1 / <b>IC ID:</b> 12270-PILOT1 / <b>IFETEL:</b> RCPFRT20-1349) ( <b>FCC ID:</b> QKWPILOT2 / <b>IC ID:</b> 12270-PILOT2) | 802.11b/g/n<br>(WPA, WPA2)  |
| Ethernet (LAN)   | RJ 45, 10/100 Mbit  |
| Wired shutdown (WSD)   | max. 28 devices/WSD chain<br><br>max. distance<br>master → slave = 109 yd / 100 m<br>slave → slave = 109 yd / 100 m |
| Modbus RTU SunSpec (2x)  | RS485 2-wire  |
| Voltage level of digital inputs  | low: min. 0 V - max. 1.8 V<br>high: min. 4.5 V - max. 28.8 V  |
| Input currents of digital inputs   | depending on the input voltage;<br>input resistance = 70 kOhm   |
| Total power for digital output (internal supply)   | 6 W at 12 V<br>(USB not connected)  |
| Power per digital output (external supply)   | 1 A at >12.5 V - 24 V<br>(max. 3 A in total)  |

| DC Input data battery <sup>4)</sup> |       |
|-------------------------------------|-------|
| Min. voltage                        | 150 V |
| Max. voltage                        | 455 V |
| Max. current                        | 22 A  |

| <b>DC Input data battery<sup>4)</sup></b> |         |
|---|---------|
| Max. output                               | 10000 W |
| DC Inputs                                 | 1       |

| <b>Output data Full Backup<sup>5)</sup></b> |          |                                   |
|---|----------|-----------------------------------|
| Nominal output power<br>Full Backup         | at 120 V | 9450 W                            |
|   | at 220 V | 10000 W                           |
|   | at 240 V | 10000 W                           |
| Max. continuous output<br>current           | at 120 V | 45.5 A                            |
|   | at 220 V | 45.5 A                            |
|   | at 240 V | 41.7 A                            |
| Nominal output frequency                    |          | 63 Hz                             |
| Power factor                                |          | 0.8 - 1 ind. / cap. <sup>2)</sup> |
| Switching time                              |          | <45 sec.                          |

## WLAN

| <b>WLAN</b>           |  |
|-----------------------|--|
| Frequency range       | 2412 - 2462 MHz  |
| Channels / power used | Channel: 1-11 b,g,n HT20<br>Channel: 3-9 HT40<br><18 dBm   |
| Modulation            | 802.11b: DSSS (1Mbps DBPSK, 2Mbps DQPSK, 5.5/11Mbps CCK)<br>802.11g: OFDM (6/9Mbps BPSK, 12/18Mbps QPSK, 24/36Mbps 16-QAM, 48/54Mbps 64-QAM)<br>802.11n: OFDM (6.5 BPSK, QPSK, 16-QAM, 64-QAM) |

## Explanation of footnotes

- 1) The maximum current from the inverter to the PV module if an error occurs in the inverter. Guaranteed by the electrical design of the inverter.
- 2) Depending on the country setup or device-specific settings (ind. = inductive; cap. = capacitive).
- 3) Assured by the electrical design of the inverter.
- 4) The inverter can be upgraded to a GEN24 Plus Hybrid device in the future through the UP.storage software upgrade. This upgrade activates battery functionality, enabling the possibility of a Full Backup power solution. However, external grid switching devices are required for this functionality. The technical specifications for battery operation and Full Backup operation are detailed below.
- 5) For Full Backup, additional external components are required for grid separation.

**Integrated DC  
disconnect**

| <b>General data</b>                                   |   |
|---|---|
| Product name  | Benedict LS32 E 7905  |
| Rated insulation voltage                              | 1000 V <sub>DC</sub>  |
| Rated impulse withstand voltage                       | 8 kV  |
| Suitability for insulation                            | Yes, DC only  |
| Utilization category and/or PV utilization category   | according to IEC/EN 60947-3 utilization category DC-PV2       |
| Rated short-time withstand current (I <sub>cw</sub> ) | Rated short-time withstand current (I <sub>cw</sub> ): 1000 A |
| Rated short-circuit capacity (I <sub>cm</sub> )       | Rated short-circuit capacity (I <sub>cm</sub> ): 1000 A       |

| <b>Rated operating current and rated breaking capacity</b> |   |  |   |  |
|--|---|--|---|--|
| Rated operating voltage (U <sub>e</sub> )                  | Rated operating current (I <sub>e</sub> ) | I <sub>(make)</sub> / I <sub>(break)</sub> | Rated operating current (I <sub>e</sub> ) | I <sub>(make)</sub> / I <sub>(break)</sub> |
| ≤ 500 V <sub>DC</sub>                                      | 14 A                                      | 56 A                                       | 36 A                                      | 144 A                                      |
| 600 V <sub>DC</sub>  | 8 A                                       | 32 A                                       | 30 A                                      | 120 A                                      |
| 700 V <sub>DC</sub>  | 3 A                                       | 12 A                                       | 26 A                                      | 88 A                                       |
| 800 V <sub>DC</sub>  | 3 A                                       | 12 A                                       | 17 A                                      | 68 A                                       |
| 900 V <sub>DC</sub>  | 2 A                                       | 8 A  | 12 A                                      | 48 A                                       |
| 1000 V <sub>DC</sub>                                       | 2 A                                       | 8 A  | 6 A                                       | 24 A                                       |
| Number of pins   | 1   | 1  | 2   | 2  |

# Circuit Diagrams



# Emergency power terminal—PV Point (OP)

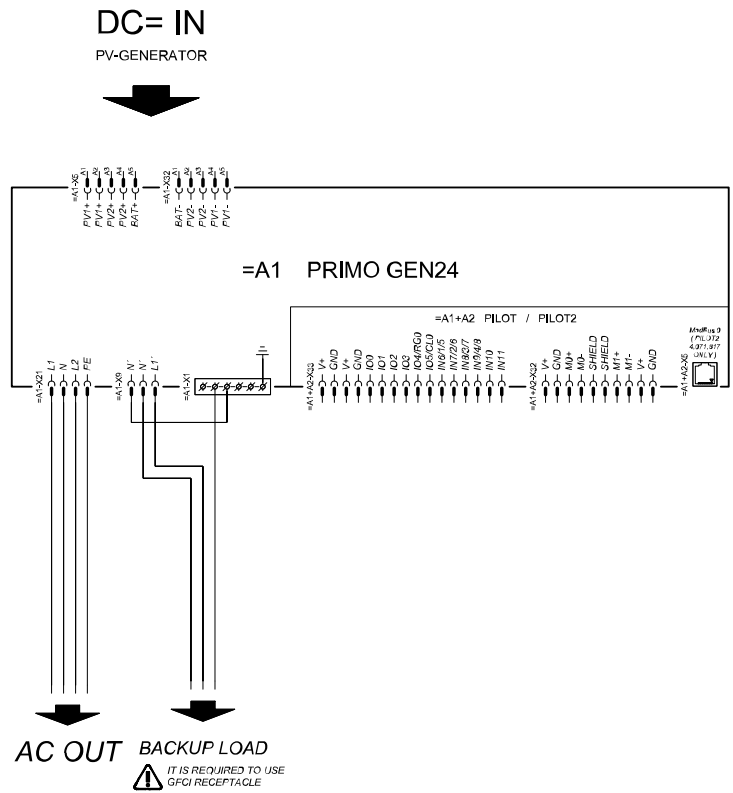





# **Dimensions of the inverter**



# Fronius Primo GEN24 7.7 - 10.0 208-240

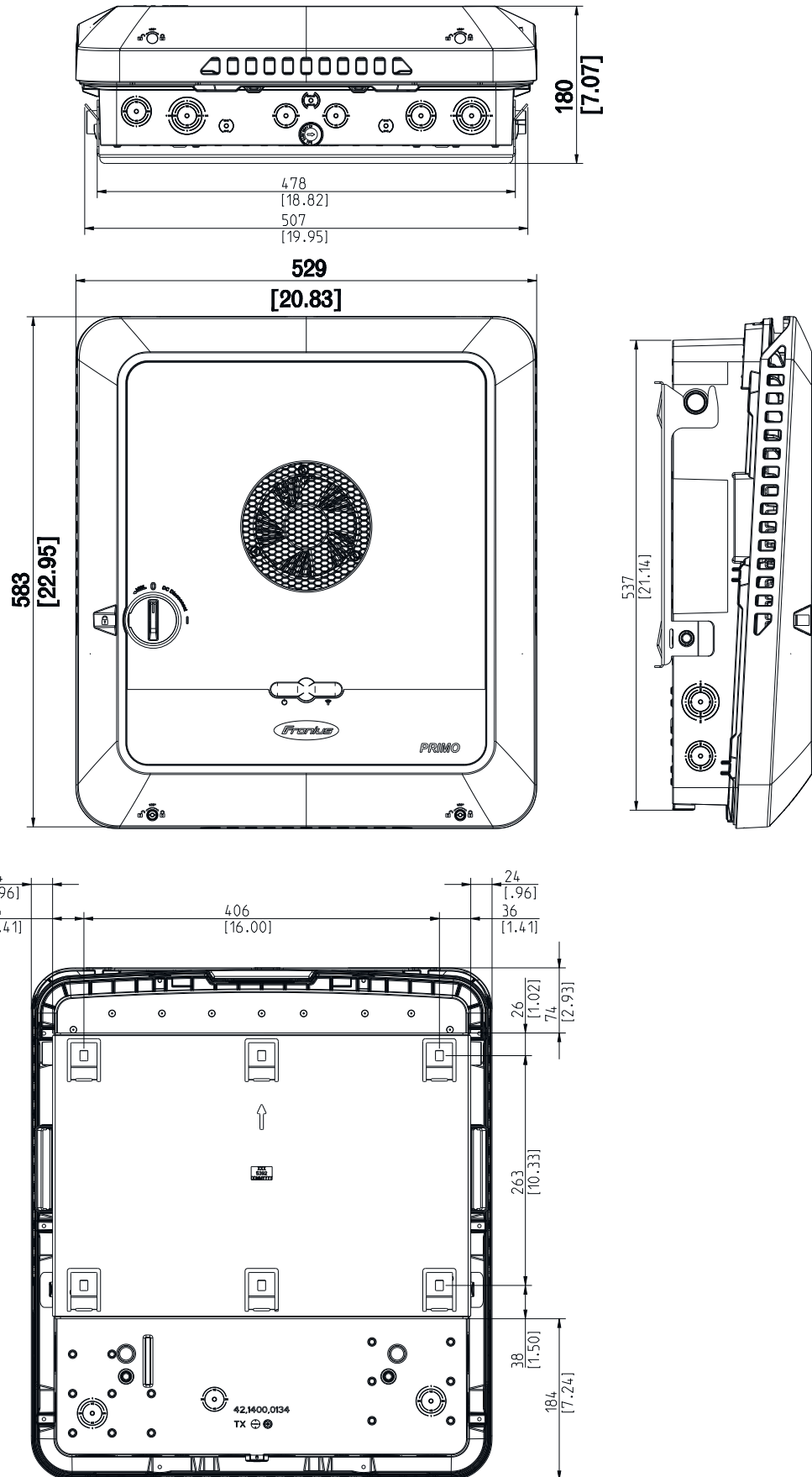



[fronius.com/en/solar-energy/installers-partners/products-solutions/monitoring-digital-tools](https://fronius.com/en/solar-energy/installers-partners/products-solutions/monitoring-digital-tools)

**MONITORING &  
DIGITAL TOOLS**

**Fronius International GmbH**

Froniusstraße 1  
4643 Pettenbach  
Austria  
[contact@fronius.com](mailto:contact@fronius.com)  
[www.fronius.com](http://www.fronius.com)

At [www.fronius.com/contact](http://www.fronius.com/contact) you will find the contact details of all Fronius subsidiaries and Sales & Service Partners.