



1 General background

Power outages can occur in several ways. Besides unintended fluctuations in voltage and frequency, which occur especially in countries with weak grid infrastructure and which can have severe impact on electrical equipment connected to these grids, they typically can be classified into two types: “low-resistance” and “high-resistance” outages.

If power outages occur in photovoltaic systems, which are connected to a grid but also have a battery as a backup power source, it is important that the battery inverter can compensate the grid failure as quickly as possible.

2 Switchover time

Switchover time of (grid-forming) voltage-controlled battery inverters is defined as the time interval between the power outage and the moment where the inverter has set up its own grid by providing sine-wave voltage and frequency.

Due to switching of relays and the internal control processes inside the inverter, this switchover time depends on the type of power outage.

Sunny Island inverters have a switchover time of 0 ms to 20 ms for SIH6.0-12/SI8.0H-12 and 0 ms to 35 ms for SI 4548-US-10/SI 6048-US-10.

1. For planned switchover, e.g. from a diesel generator, the switchover time for an Sunny Island is 0 ms.
2. For high-resistance power outages, i.e. clear power cut or voltage and frequency deviations, the switchover time of an Sunny Island is 0 ms.
3. For low-resistance power outages, i.e. short cut near by in the public grid or on the diesel generator side, the switchover time is typically 35 ms for the SI 4548-US-10/SI 6048-US-10. The switchover time for SI6.0H-12/SI8.0H-12 has been improved to 20 ms for both one- and three-phase systems thanks to an optimized software algorithm (from firmware version 1.03.00.R).

These values have been tested in our laboratories under certified test conditions and are in line with our observations from real-life reference plants.

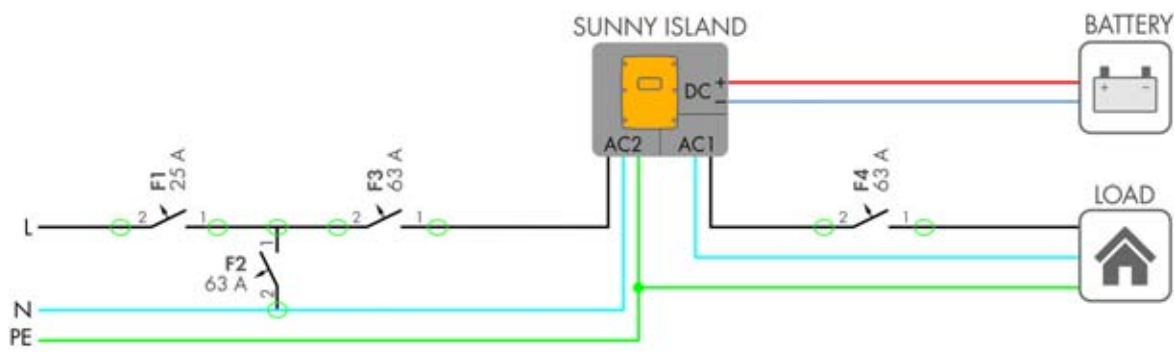

Figure 1: General setup to simulate a power outage.

- Low-resistance power outage; F1; F3 and F4 are closed; F2 is open. To simulate a short circuit, F2 will be closed.
- High-resistance power output; F1; F3 and F4 are closed; F2 is open. To simulate a grid failure, F3 will be opened.