



SUNNY BOY SMART ENERGY

Approved batteries and information on connecting batteries

1 Validity

This document is valid for:

- SBSE3.8-US-50 (Sunny Boy Smart Energy 3.8-US)
- SBSE4.8-US-50 (Sunny Boy Smart Energy 4.8-US)
- SBSE5.8-US-50 (Sunny Boy Smart Energy 5.8-US)
- SBSE7.7-US-50 (Sunny Boy Smart Energy 7.7-US)

2 Approved Batteries

You can find the batteries approved by SMA Solar Technology AG in the SMA Energy Solution Home with the Sunny Boy Smart Energy in the following table.

i Firmware version of the battery

The firmware versions of the batteries can be viewed via the user interface of the respective battery after successful commissioning. For BYD batteries, the firmware of the batteries is updated via the user interface of the battery (see manufacturer's manual).

i Inverter firmware version

The firmware version of the inverter can be accessed via the user interface of the inverter.

Type (manufacturer)	System designation according to UL9540	Firmware version of the battery	Inverter firmware version
Battery-Box Premium HVL (12.0-32.0) (BYD Company Limited)	<ul style="list-style-type: none"> • SMA-SBSE-3.8-ESS-HVL • SMA-SBSE-4.8-ESS-HVL • SMA-SBSE-5.8-ESS-HVL • SMA-SBSE-7.7-ESS-HVL 	BMU: ≥ 3.23 BMS: ≥ 3.28	$\geq 3.06.15.R$

3 Battery Communication Connection

3.1 Pin assignment of RJ45 plug connector for battery communication

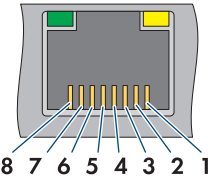
RJ45 plug	Pin	Signal
	1	-
	2	EN_GND
	3	-
	4	CAN_H
	5	CAN_L
	6	-
	7	BAT_EN
	8	-

3.2 Battery Communication Cable Requirements

The cable length and quality affect the quality of the signal. Observe the following cable requirements:

- Cable type: 100BaseTx
- Cable category: minimum CAT5e
- Plug type: RJ45 of Cat5e or higher
- Shielding: SF/UTP, S/UTP, SF/FTP or S/FTP
- Number of insulated conductor pairs and insulated conductor cross-section: at least 2 x 2 x 0.34 mm² (2 x 2 x 22 AWG)
- Maximum cable length between 2 nodes when using patch and installation cables: 10 m (33 ft)
- UV-resistant if installed outdoors.

3.3 Cabling plan with Battery-Box Premium HVL

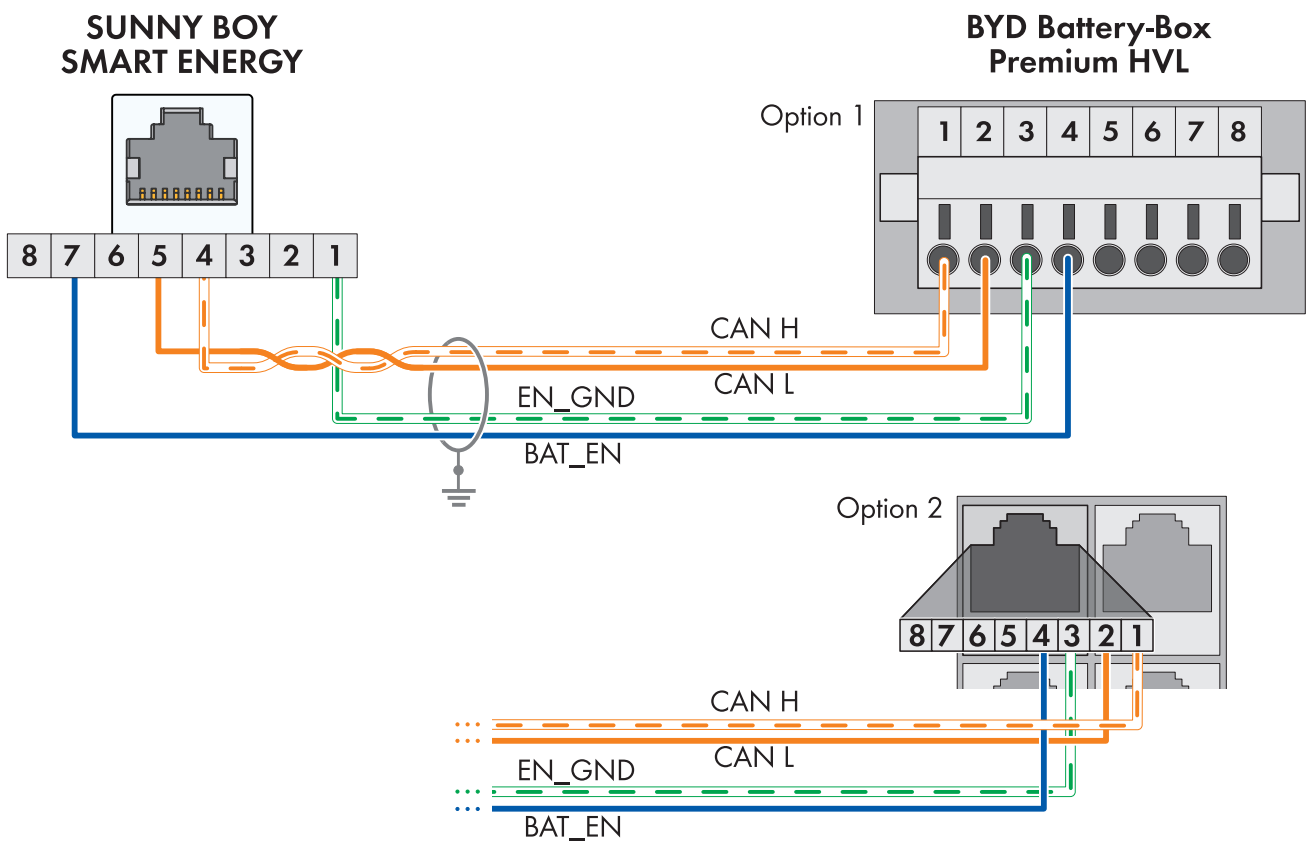

Figure 1: Cabling plan SBSE3.8-US-50 / SBSE4.8-US-50 / SBSE5.8-US-50 / SBSE7.7-US-50 with Battery-Box Premium HVL

Pin at the RJ45 connector on the inverter	Signal	Terminal point at battery
1	-	-
2	EN_GND	3
3	-	-
4	CAN_H	1
5	CAN_L	2

Pin at the RJ45 connector on the inverter	Signal	Terminal point at battery
6	-	-
7	BAT_EN	4
8	-	-

ENERGY
THAT
CHANGES



www.SMA-Solar.com

